

Application of the Open Cycle Stirling Engine Driven with Liquid Nitrogen for the Non-Polluting Automobiles

M.B. Kravchenko

Odessa National Academy of Food Technologies, 112 Kanatnaya str., Odessa, 65039, Ukraine.

e-mail: kravtchenko@i.ua.

Progress on advancing technology of using liquid nitrogen for the non-polluting automobiles is reported. It is shown that the low exergy efficiency of the known engines fueled with liquid nitrogen has discredited the very idea of a cryomobile. The design of the open-cycle cryogenic Stirling engine is proposed. This engine allows extracting up to 57% of the exergy accumulated in liquid nitrogen. The method used to calculate of such open-cycle Stirling engine is described and the calculation results and discussion are presented. It is shown that 200 liters of liquid nitrogen is sufficient for 180 km range of cryomobile at speed of 55 km/h, while a full charge of the 300-kilogram battery of Nissan LEAF electric vehicle is sufficient for a range of 160 km. Use of liquid nitrogen or liquid air as an energy vector in a transport will not require scarce materials, and, in comparison with using of lithium-ion batteries or hydrogen, this will require less capital investment.

Keywords: Heat engines; Zero emission vehicles; Liquid nitrogen; Liquid air; Cryogenic; Stirling engine.

Застосування двигуна стірлінга, що працює на рідкому азоті, для створення екологічно чистих автомобілів

М. Б. Кравченко

Одеська національна академія харчових технологій, вул. Канатна, 112, Одеса, 65039, Україна

У статті наведений огляд сучасного стану розвитку технології використання рідкого азоту для створення екологічно чистих автомобілів. Показано, що низька ексергетична ефективність двигунів, що працюють на рідкому азоті, дискредитувала саму ідею кріомобіля. Запропоновано конструкцію кріогенного двигуна, який працює по відкритому циклу Стірлінга. Цей двигун дозволяє вилучати до 57% ексергії, накопиченої у рідкому азоті. Описана методика обчислення основних характеристик такого двигуна і наведені результати його розрахунків. Показано, що 200 літрів рідкого азоту достатньо для 180 км пробігу кріомобіля зі швидкістю 55 км/год., тоді як повний заряд 300-кілограмового акумулятора електромобіля Nissan LEAF достатній лише для пробігу 160 км. Використання рідкого азоту або рідкого повітря в якості енергоносія на транспорті не вимагатиме використання дефіцитних матеріалів, і, в порівнянні з використанням літій-іонних батарей або водню, вимагатиме менших капіталовкладень.

Ключові слова: тепловий двигун; екологічно чисті автомобілі; рідкий азот; рідке повітря; кріогенна техніка; двигун Стірлінга.

© The Author(s) 2017. This article is an open access publication

This work is licensed under the Creative Commons Attribution 4.0 International License (CC BY)

<http://creativecommons.org/licenses/by/4.0/>

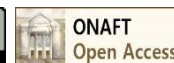

1 Introduction

At present, the world energy industry is experiencing the technological revolution connected with explosive growth of the renewable energy sources. This is illustrated in Figure 1, which shows the change in the share of energy received from renewable sources in the energy balance of Germany for the period 1991-2016.

Now the share of renewable energy sources in the energy balance of many European countries exceeds 20%. In 2016, 191 billion kW-h of electricity was generated from renewable energy sources in Germany. It comes to 32% of the total amount of electricity consumed in this country [1]. Spain and Germany set a goal of receiving more than 50% of electricity from renewable sources until to 2030.

To completely abandon fossil fuels it will be necessary to find an intermediate energy carrier that could be used in a transport. The accumulation of this intermediate energy carrier during periods with surplus electricity in the grid is also solution to the problem of reconciling the demand and production of electricity received from renewable sources.

There are at least three competing projects to solve the problem of an intermediate energy carrier suitable for use in a transport. The most advanced is the project of electric-driven car with lithium-ion batteries. In this case, the role of the intermediate energy vector performs by lithium, which accumulated in the lithium-ion battery when it is charged.

Electric-drive vehicles have several benefits in

comparison with conventional cars, running on gasoline, diesel or gas. They are almost noiseless, easy to manage and reliable and reduce emissions of greenhouse gases. The operation of electric vehicle is much cheaper than the operation of a traditional car, because electricity is much cheaper than gasoline or diesel fuel. The main advantage of an electric vehicle is environmental safety and zero greenhouse gas emission when using electricity from renewable sources to charge the batteries.

Electric-driven vehicles have a long history of improvement. At the beginning of the 20-th century, the number of electric vehicles sold each year was about the same as the number of conventional cars sold. However, with the improvement of gasoline and diesel engines, the share of electric vehicles in the vehicle market was declining. The main reason for the abandonment of electric vehicles were low efficiency of its batteries that did not allow electric vehicles accelerate to high speed and, at the same time, to have sufficient range without recharging the batteries.

The situation changed with the advent of lithium-ion batteries, capable to provide the capacity necessary for an electric vehicle at acceptable dimensions and weight. Despite the unique characteristics of lithium-ion batteries, they remain the weak point of the electric vehicle.

First, lithium-ion batteries are very expensive; their cost is 500-600 USD per kW-h. Therefore, in modern electric vehicles, the cost of a battery is about 30-40% of the cost of the car itself.

Secondly, lithium-ion batteries are not durable, after 3-5 years of intensive operation their capacity drops, and they need to be replaced.

Thirdly, lithium-ion batteries can not be quickly charged. For example, the battery charging time of the most popular brand of electric car Nissan Leaf not less than nine hours. Even with such a prolonged charging of an electric vehicle, a significant load is created on household electric grids.

And, finally, lithium, which is necessary to manufacture batteries, is a scarce material, most of which is mined in just three countries: Chile, China and Australia.

In March 2015, Ilon Mask presented his new electric vehicle – Tesla Model 3, and said that by 2018 his company intends to sell 500,000 such cars, but "for this, it will be necessary to buy all the lithium produced in the

world." After this statement, the prices for lithium have soared. The cost of this raw material in terms of lithium carbonate in May 2016 has reached \$ 20,000 per ton versus \$ 6,000 per ton in early 2015.

"Goldman Sachs" top strategists predict that in connection with the growth in sales of electric vehicles by 2025, lithium consumption can to reach 570 thousand tons, while in 2012 it was produced only 26.5 thousand tons of lithium.

Thus, replacing the existing car fleet with electric vehicles will require a significant increase in electricity supply, as well as a significant increase in the production a number of scarce materials, such as lithium and copper.

The second project, implementation of which can lead to abandonment of fossil fuels in transport, is the use of hydrogen as a clean energy carrier [2, 3].

Hydrogen energy was formed in the mid-1970s as one of directions of scientific and technological progress. Starting of the works into controlled thermonuclear fusion lent impetus to researches related to the production, storage, transportation and use of hydrogen. At that time it was believed that these works would quickly lead to the development of reactors with controlled thermonuclear fusion, which would ensure the production of a large amount of cheap electricity.

Hydrogen was chosen as an intermediate energy carrier because of its obvious environmental benefits. In the presence of cheap electricity, hydrogen was planned to be obtained by electrolysis of water.

Electrolysis of water is one of the most well studied methods to obtaining hydrogen. The electrochemical method of obtaining hydrogen from water has the following positive qualities:

- high purity of the produced hydrogen – up to 99.99% and higher;
- simplicity of the technological process, its continuity and the possibility of a full automation;
- always available and practically inexhaustible raw material – water;
- flexibility of the process and possibility to obtaining hydrogen directly under pressure;
- possibility to obtain valuable by-products – heavy water and oxygen.

Despite the fact that hopes for the rapid development of nuclear fusion technology have not implemented,

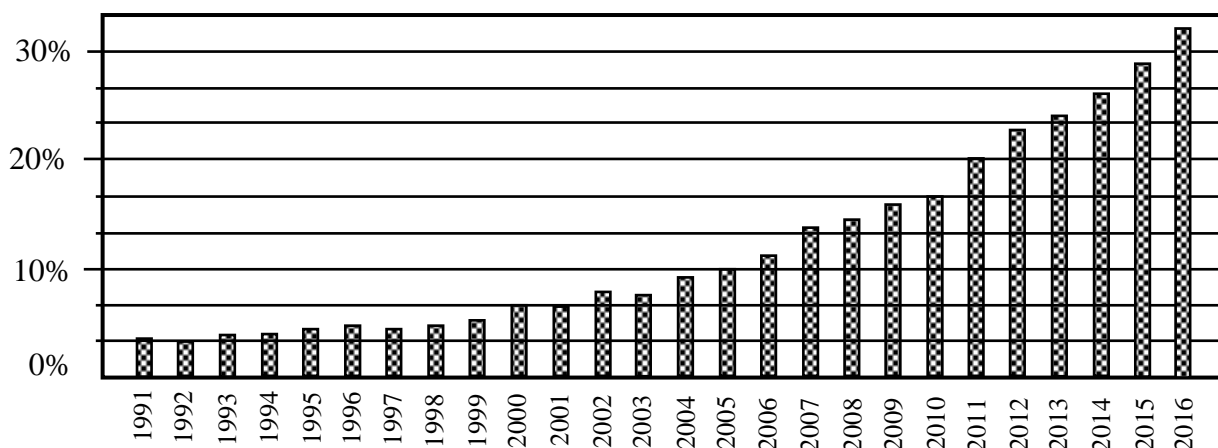

Figure 1 – Share of energy, received from renewable sources in Germany for 1991-2016.

significant achievements in the hydrogen energy have been in demand in a world, which is preparing for the transition to use renewable energy sources.

When hydrogen is used as an energy vector on the transport, in addition to absolute environmental purity, it has a number of others advantages.

First, existing internal combustion engines can be converted to hydrogen, and this requires minimal changes in engine design.

In addition, the chemical energy of hydrogen can be converted into electricity in the so-called fuel cells. When hydrogen is dissolved in metals, for example in platinum, the proton and the electron that make up the hydrogen atom are separated. If the platinum electrode is in an alkaline medium, then it reacts to form free electrons:

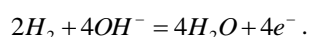

In a fuel cell, these electrons pass through an electrical circuit and perform useful work. After that, the electrons get to another electrode, where the next reaction occurs with participation of the oxygen:

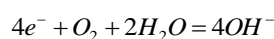

This way of using hydrogen is much more efficient than its combustion in the internal combustion engine. The efficiency of conversion chemical energy into useful work in fuel cells is much higher and reaches 80%. The main disadvantage of this process is the high cost of platinum or palladium electrodes in the fuel cells.

Several decades of research aimed to improve design of fuel cells led to creation of compact, reliable and efficient sources of current, but this efficiency is based on the unique properties of platinum, which is still used for the production of electrodes. Therefore fuel cells remain expensive; their cost is about \$1500 per kW.

In addition, the using of hydrogen as an energy vector has a number of significant drawbacks. First in the list of hydrogen drawbacks are the fire and explosion hazards.

Traditional types of fuels used in transport (gasoline, diesel fuel and natural gas) are the flammable and explosive substances. But hydrogen, even against such background, is a highly flammable and explosive substance. For example, a mixture of methane and air under normal conditions ignites if volume fraction of methane is within the range of 5.3-15%, and detonates at volume fraction of 6.3-13%. The mixture of hydrogen with air ignites and detonates in a much larger range of volumetric hydrogen concentrations, respectively – 4.1-75% and 18.3-74%.

The thermal impulse (the energy of ignition) necessary for the ignition of combustible substances is, for mixtures of methane with air, $E_0=280 \cdot 10^{-6}$ J, and for hydrogen-air mixtures $E_0=19.6 \cdot 10^{-6}$ J. The energy that initiates the reaction of hydrogen with air is so small that the ignition of hydrogen can occur even from spark of static electricity accumulated on clothing. Therefore, when working with hydrogen, it is not allowed to wear synthetic clothing.

The TNT equivalents of the explosion of stoichiometric mixtures of methane and hydrogen with air are 4.8 and 10.6 kg of trinitrotoluene per kilogram of product, respectively.

Another disadvantage of hydrogen as an energy carrier is the complexity of its accumulation and storage. Hydrogen is the lightest gas, therefore its storage and transport in cylinders is extremely irrational. If 9 kg of oxygen can be pumped into a standard cylinder, then only 0.48 kg of hydrogen will fit in the same cylinder.

Liquefying of hydrogen can increase its density, but liquid hydrogen is also a very light liquid. The density of liquid hydrogen is only 70.9 kg/m^3 .

Hydrogen liquefaction is a very energy-expensive process, since the normal boiling temperature of hydrogen is only 20.4 K. If we add to this carrying out the ortho-para conversion, which is needed to ensure the long-term storage of liquid hydrogen, then the high cost of the infrastructure to use liquid hydrogen in transport becomes clear.

Despite these drawbacks of hydrogen, a number of leading automotive companies have developed and produce a limited number of cars running on hydrogen. The most famous of these models are: Honda FCX Clarity, Mercedes-Benz F-CELL, BMW Hydrogen 7, Mazda RX-8 hydrogen (see Figure 2).

Liquid air or liquid nitrogen comparatively recent has to be considered as a potential intermediate energy carrier, which can be used in transport.

The idea of using the liquid air as an energy vector for a car appeared shortly after industrial air-liquefaction plants were created.

The first prototype of a car fueled with liquid air was shown in 1902 and was called “Liquid Air” (see Figure 3) [4]. In this photo, “Liquid Air” is driven by its inventor – the Dane, Hans Knudsen. The car was able to drive 64 kilometers through the streets of London at a speed of 19 kilometers per hour, spending on it 64 liters of liquid air. According to experts, energy efficiency of this cryomobile was only about 4%.

The next attempt to create a car fueled with liquid air was made in the United States, in 1914. Two managers of Buick company – William Little and William Durant create experimental cryomobile, which they called “Little” (see Figure 4). As the engine of this model converted 4-cylinder internal combustion engine was used. In the process of testing, the cryomobile demonstrated its working capacity, but did not attract investors, in particular, due to lack of infrastructure for refueling the cryomobile with liquid air.

The idea of a car running on liquid nitrogen returned



Figure 2 – Car BMW Hydrogen 7, working on hydrogen

only in the 90-s of the last century, when the question arose about developing a car with zero emissions.



Figure 3 – The first car working on liquid air, and its inventor – Hans Knudsen



Figure 4 – “Little” – cryomobile working on liquid air (1914)

In 2000, a group of scientists from the University of Washington developed and tested experimental car operating on liquid nitrogen, which they called the LN2000 (see Figure 5).



Figure 5 – LN2000 – experimental model of cryomobile operating on liquid nitrogen

The experimental cryomobile was created on the basis of the serial electric vehicle Grumman Kubvan. As the engine it was used the ship pneumatic motor, intended for a lifting and lowering anchor. Power of the air motor was 11 kW [5].

On a tests cryomobile developed speed up to 35 kilometers per hour. Measurement of the flow rate of liquid nitrogen showed that efficiency of the power installation of this cryomobile reaches 9%.

Schematic diagram of the LN2000 cryomobile power installation is shown in Figure 6. It includes a Dewar vessel 1 for storing liquid nitrogen, liquid nitrogen pump 2, economizer 3, atmospheric heat exchanger 4 and expansion machine 6. Power of expansion machine via transmission transferred to the wheels of the cryomobile.

The scheme of this cryomobile, like in all previous models, is the same as for a steam locomotive, but instead of water, liquid nitrogen is used.

Therefore, it is not surprising that the efficiency of the power installations of such cryomobiles was about the same as efficiency of a locomotive – less than 10%. The low efficiency of power installations used in the known samples of cars working on liquid nitrogen or liquid air discredited the very idea of the cryomobile [6, 7, 8, and 9]. Therefore, public interest and the financing of cars running on liquid nitrogen is much less than interest in electric vehicles or cars running on hydrogen.

In 2001, the British inventor Peter Dearman proposed a new engine design for the use of liquid nitrogen energy. The experimental model of the Dearman engine has accelerated its cryomobile, assembled on the basis of the Ford Fiesta car, to 50 km/h.

The main feature of the Dearman engine is the contact heat exchange of the liquid heat transfer agent with liquid nitrogen directly in the working cylinder of engine. This makes it possible to realize the process of nitrogen expansion close to isothermal, and due to this, it is essential to increase the efficiency of the machine [10].

In Figure 7 shows the principle of operation of Dearman engine. The working process in Dearman engine

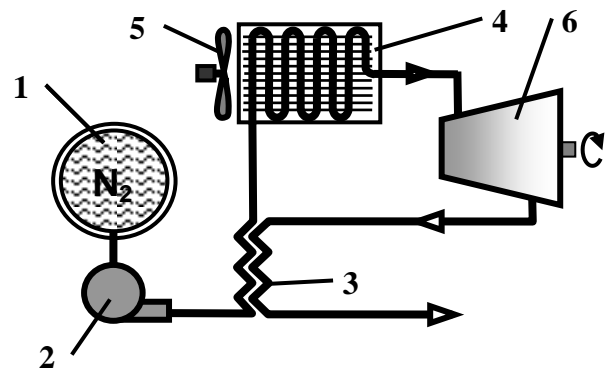

1 – Dewar vessel for storage of liquid nitrogen; 2 – liquid nitrogen pump; 3 – economizer; 4 – atmospheric heat exchanger; 5 – the fan; 6 – expansion machine.

Figure 6 – Schematic diagram of the LN2000 cryomobile power unit.

consists of four stages. At the first stage (Figure 7a), when the piston moves upward, a liquid heat transfer agent is supplied in the cylinder.

At the top dead center, liquid nitrogen is injected into the engine cylinder (Figure 7b). When a jet of liquid

nitrogen flows into the liquid heat transfer agent, a quick boiling of liquid nitrogen is occurs. As a result of the intense boiling of nitrogen, the pressure in the cylinder increases, and the expanding vapors of liquid nitrogen pushing the piston of the engine downward (Figure 7c). Near the bottom dead center, the piston opens a window in the cylinder through which a mixture of expanded nitrogen vapors and droplets of heat-transfer liquid leaves the cylinder (Figure 7d).

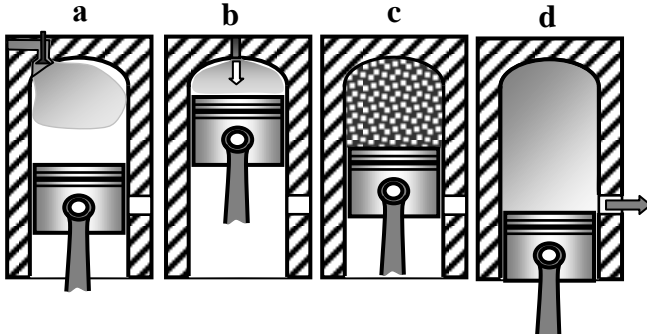

Figure 7 – Principle of the Dearman engine.
a – inlet of the heat-transfer liquid; *b* – injection of liquid nitrogen; *c* – working stroke; *d* – release of the expanded vapors of nitrogen and drops of heat-transfer liquid.

As a "garage inventor" Dearman went beyond the stereotypes that were formed by engineers in the course of their practical activities. One of these stereotypes is that there should be no liquid in the engine cylinder. The presence of fluid in the cylinder can lead to a hydraulic shock, which usually ends up damaging the machine. Dearman managed to create the working piston engine, which has liquid in the cylinder constantly.

Another stereotype of thinking, which Dearman destroyed, is that the engine for the car running on liquid nitrogen, shut be a pneumatic motor – a machine that converts the energy of compressed air into mechanical work. He was creating the first machine that converts the energy of liquid nitrogen into mechanical work.

2 Thermodynamic analysis of the engine working on liquid nitrogen

The maximum work that can be obtained by interaction of a cryogenic liquid with the environment is equal to the minimum theoretical work for liquefaction of this cryogenic liquid.

Minimum work for liquefaction it is the work of ideal liquefaction cycle for a definite substance at present environmental parameters.

An ideal liquefaction cycle is a cycle composed of isobar of liquefy substance at ambient pressure, isotherm for this substance at ambient temperature, and adiabatic process which closing this cycle.

In Figure 8 is shown the pattern of ideal liquefaction cycle in the temperature-entropy diagram. As is known, the area of the thermodynamic cycle on the temperature-entropy diagram represents the work spent in this cycle. Consequently, the minimum work required to liquefaction

of gas, in direct proportion to the area of the shape 1-2-3-4. It is easy to calculate, that the minimum work required to nitrogen liquefaction at ambient temperature 293 K and atmospheric pressure (760 mmHg) is equal to 741 kJ/kg or 183.7 kW-h/kg. This value determines the maximum work that can be obtained by the interaction of liquid nitrogen with the environment.

In Figure 8 also shown the thermodynamic cycle that was used in the LN2000 cryomobile, it is the cycle 1-8-9-2.

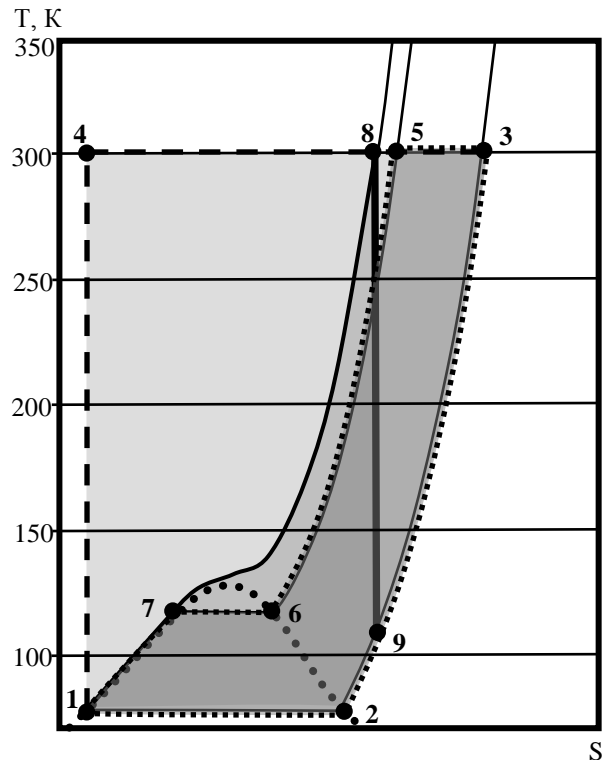

Figure 8 – Ideal cycle of nitrogen liquefaction and cycles of cryomobiles power installations in the temperature-entropy diagram.

- 1-2-3-4 – ideal cycle of nitrogen liquefaction;
- 1-8-9-2 – cycle of the LN2000 power unit;
- 1-7-6-5-3-2 – cycle of the Dearman engine.

Therefore, comparing the areas of different cycles, you can get a visual representation of the potential of a particular cycle. From this figure, we notice that the single-stage adiabatic expansion, which used in the LN2000 cryomobile, is extremely inefficient. Thermodynamic losses in this cycle could be reduced by applying a multistage expansion of nitrogen with intermediate heating from the environment.

The realization of nitrogen expansion process close to the isothermal in the Dearman engine makes it possible to essentially increase the work obtained with nitrogen expansion. From this temperature-entropy diagram we can notice that the area of the figure 1-7-6-5-3-2, which corresponds to work in the Dearman cycle, is larger than the area of the cycle used in the LN2000 cryomobile. Comparison of the areas of the Dearman cycle and the cycle of the LN2000 cryomobile with the area of the ideal nitrogen liquefaction cycle indicates that both these cycles are far from ideal.

To estimate the theoretical potential of a cryomobile it is enough to compare the minimum work required to liquefaction of nitrogen with the specific capacitance of certain types of electrical accumulators. The below figure 9 shows a comparison between the specific energy accumulated in different types of electrical accumulators with the maximum work that can be obtained by the interaction of liquid nitrogen with the environment.

It is obvious, that liquid nitrogen as an intermediate energy carrier is in no way inferior to existing batteries. But this is possible under the condition a method of efficient extraction of energy from liquid nitrogen will be found.

The figure 9 shows that the capacity of existing batteries is strongly dependent on the power that this battery emits to the network. This is due to the fact that all batteries have an internal electrical resistance. When an electric current flows in the circuit to which the battery is connected, some of the electricity supplied by the battery is lost inside it, turning into the heat. From Figure 9 we can notice that lead batteries have internal resistance less than other types of batteries, so this type of battery can give more power to the electrical circuit. In lithium-ion batteries, the internal resistance is relatively large, so the capacity of this type of battery is highly dependent on the output power or the discharge rate.

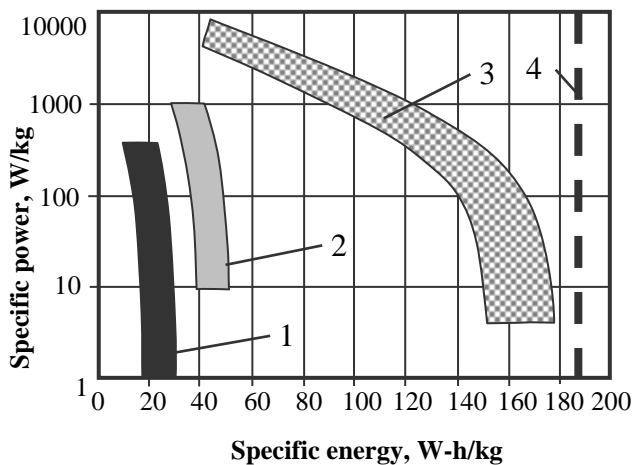

1 – lead accumulators; 2 – nickel-cadmium batteries;
3 – lithium-ion batteries; 4 – work that can be obtained from 1 kg liquid nitrogen.

Figure 9 – Comparison of the specific energy accumulated in various types of accumulators with the maximum work that can be obtained by the interaction of liquid nitrogen with the environment.

The most widespread electric car Nissan Leaf has a lithium-ion battery with capacity is 24 kWh, and the battery weight is 300 kg. Hence, it is not difficult to calculate the actual value of the specific capacity of lithium-ion batteries, which are used in electric vehicles – 0.08 kW-h/kg. It follows that if you can create a machine that will extract at least 50% of the energy stored in liquid nitrogen, then cryomobile will outperform the electric cars.

3 Open-cycle Stirling engine

The concept of the open-cycle Stirling engine is not new. For example, Isshiki et.al. [11, 12] developed the steam Stirling engine, which operates as a hybrid of the Stirling machine and the Rankine steam-operated cycle. This engine has one cylinder with a power piston and a heater at the top, and a second cylinder in which displacer moves. Between these two cylinders, there is a regenerative heat exchanger like in the Stirling machine. But besides this, the Isshiki engine has intake and exhaust valves through which the steam enters the cylinder, expands in it and is ejected from the working cylinder. The same as in the Rankine cycle, the spent steam is condensed, pumped into the steam boiler and again fed into the power cylinder.

When the Isshiki engine is running, saturated steam from the external boiler enters the power cylinder when the piston approaches to the top dead center. Subsequently steam passes through the regenerator and the heater, and then expands at an almost constant high temperature. Further, the expanded steam passes through the regenerator and vent to the condenser, where it condenses and is again pumped into the boiler.

In experiment performed on the miniature size prototype operating on overheated steam with pressure of 0.2 MPa and temperature of 250 °C, output power of 12 W was obtained. This is approximately five times greater than the power of a Stirling gas engine of the same dimensions, operating at 320 °C [11].

The following article appeared in the 2014, it presented the results of mathematical modeling and experimental research of the prototype of the steam Stirling engine, which has a beta-type configuration. In Figure 10 shows the scheme of the steam Stirling engine, or "isothermal expansion machine" from [13].

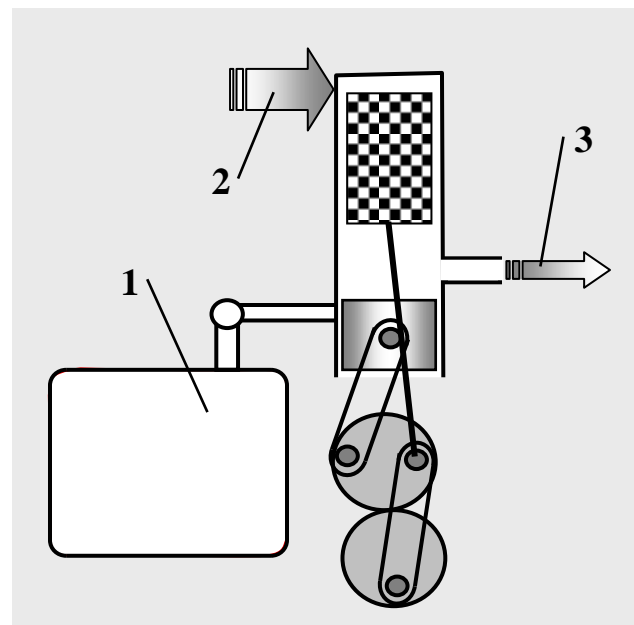

1 – steam boiler; 2 – supply of heat; 3 – exhaust steam.

Figure 10 – Scheme of steam Stirling engine [13].

The experimental sample of the engine had working volume of 100 cm³. This model was allowed to regulate the

phase shift of the piston and displacer motion. In the experimental study of this engine, it was shown that it develops the greatest power with the phase shift of piston and displacer motion is equal to 20 angular degrees.

Since in this work was studied an "isothermal expansion machine", that the main attention was paid to increasing its power. The questions of the thermodynamic perfection of this machine went to the background and were not studied.

In the article of Weiqing et al. [14] the scheme of open-cycle Stirling engine operating at liquid nitrogen is described. The authors of this work proposed to combine the reservoir for storage of liquid nitrogen with a cold cavity of the Stirling engine. In this engine, which has a gamma-type configuration, nitrogen vapors, produced by the engine, run through the regenerative heat exchanger and are released into the environment from the warm part of the engine.

Unfortunately, this design of Stirling engine, working at liquid nitrogen, is not functioning. Because, during the engine operation the pressure swing of gaseous nitrogen above the surface of liquid nitrogen have supposedly with amplitude up to 5 bar, per one revolution of the shaft. The mathematical model of the engine, given in the article, also does not take into account the possibility of condensation of nitrogen vapors with increasing their pressure above the surface of the liquid.

Despite this, the main idea stated in this article is that to convert the exergy of liquid nitrogen into mechanical work, it is necessary to utilize not only the energy of gas pressure, but also the cold exergy of the liquid nitrogen is certainly correct.

In the proposed design of the open-cycle Stirling engine, nitrogen is also used as the working substance. Moreover, most of this nitrogen involved in a closed thermodynamic cycle, and a smaller part passes through the engine. This part of nitrogen is used as a cold source in the heat engine.

The transit part of nitrogen enters in the cold cavity of engine and exits it from the warm side of the Stirling engine. The principle of operation of the proposed Stirling machine working on an open cycle is shown in Figure 11.

Nitrogen injection occurs when most of the working substance is in the cold cavity of the cylinder and gas from the cold part of the cylinder begins to move into its warm part (see Figure 11a). Since the nitrogen pressure in this phase of the cycle is above the critical, the injected nitrogen will be a cold supercritical fluid that almost instantaneously mixes with the nitrogen in the cylinder. As a result of this mixing, the temperature of nitrogen in the cold cavity will decrease, and the mass of the working substance in the engine will increase. Calculations show that the optimum amount of injected nitrogen is 8-10% of the mass of the working substance already present in the Stirling machine.

At the next stage of the machine operation, due to moving of the displacer, nitrogen is pushed into the warm cavity of the Stirling engine (see Figure 11b). At the same time, the working substance obtained heat from environment.

Then, the expansion of nitrogen at a temperature close to the ambient temperature follows (see Figure 11c). Expansion of gas is accompanied by the production of useful work.

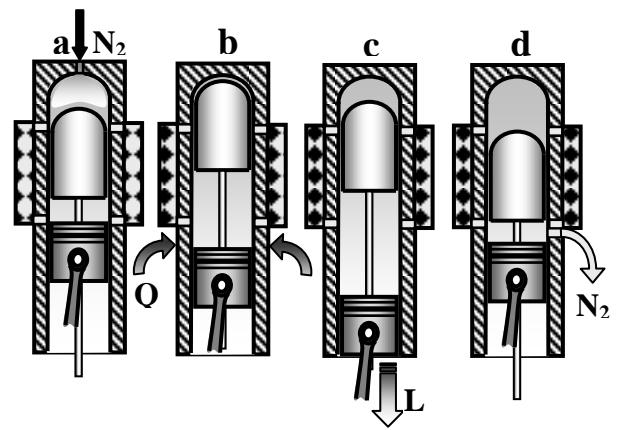

Figure 11 – The principle of operation of Stirling machine with open cycle.

a – injection of nitrogen into the cold cavity of the Stirling engine; *b* – displacement of nitrogen into a warm cavity with the supply of heat from the environment; *c* – expansion of nitrogen in the warm cavity with production of useful work; *d* – exhaust of nitrogen at the minimum pressure in the engine.

At the last stroke of the proposed Stirling engine, due to moving of the displacer into the warm part of the cylinder, gas is pushed into the cold cavity (see Fig. 11d). This process is accompanied by decreasing the pressure in the cylinder. When the cylinder's minimum pressure is reached, the exhaust valve opens. Through open exhaust valve a portion of nitrogen is discharged from the engine. Thus, the mass of the nitrogen, participating in the operation of the machine returns to its original value. After that, the cycle repeats.

As is known, the lower the temperature at which gas is compressed, the less energy it will take to compress this gas. In the Stirling machine under consideration, the working substance is compressed at a low temperature, and then expands at a higher temperature. Therefore, for one rotation of the shaft, the total energy balance will be positive. It follows that the machine will operate as a heat engine.

To evaluate the possibilities of the proposed cycle, it is necessary to simulate the operation of the Stirling machine operating on the proposed cycle.

Before constructing the mathematical model of proposed machine, its basic parameters were set. The main dimensions of the simulated machine are the same as those of the legendary PLA-107 cryogenic Stirling machine. This machine was developed by the Philips in 1954 and with small improvements is being released to the present time. The choice of this machine is due to that all its characteristics are well known. In addition, this machine is extremely reliable, because it is a result of long term improvement and optimization. For example, the four-cylinder machine of this type, established in 1967 in the University of Brussels, has worked 192,000 hours.

The selected machine has a beta-type configuration, so it has one cylinder in which the piston and displacer moves coaxially. The beta configuration of the Stirling machine is compact. Therefore it is best suited for transport use.

The main dimensions of the machine are chosen as follows: piston diameter 80 mm, displacer diameter 70 mm, piston stroke 52 mm, displacer stroke 30 mm. The dead volume is assumed equal to 70 cm³. The phase shift between the movements of the piston and the displacer is 70 angular degrees. Stationary gas pressure in this machine is 19 bars.

The temperature in the warm cavity of the machine is assumed to be equal to 250 K. Such low temperature makes it possible to supply heat from an intermediate coolant interacting with the environment.

The temperature of the cold part of the machine is assumed to be 130 K.

In the process of modeling this machine, the complete revolution of its crankshaft was divided into 180 parts, each corresponding to the rotation for 2 angular degrees. Further, in each of these positions of crankshaft, the volumes of warm and cold cavities are calculated.

Knowing the volumes of warm and cold cavities, as well as the gas temperature in these cavities, and using the material balance equation, finding the current value of pressure in the machine by the formula:

$$P(\varphi) = \frac{M \cdot R}{\mu \left[\frac{V_c(\varphi)}{T_c} + \frac{V_h(\varphi)}{T_h} + \frac{2V_o(\varphi)}{T_h + T_x} \right] c}$$

where M – is the total mass of nitrogen in the machine; V_c – is the volume of the cold cavity; V_h – is the volume of a warm cavity; V_o – is the dead volume; T_c – cold cavity temperature; T_h – temperature of a warm cavity; R – is the universal gas constant; μ – is the molar mass of nitrogen; φ – is the angle of the shaft rotation.

On the pressure in the Stirling machine, the work of gas expansion in the warm and cold cavities of the engine was determined. The work to be done by the gas is determined by the trapezoidal rule:

$$L = \int_{v_1}^{v_2} P(v) dV \approx P_1 \Delta V + \frac{\Delta P \Delta V}{2},$$

where P_1 – is the pressure in the engine at the beginning of the section under consideration; ΔP and ΔV – the pressure change and changing of cavity volume in the corresponding position, respectively.

The total work of gas compression in the cold cavity of the engine is equal the amount of heat that must be draw away from the cold cavity to execute a heat balance of the engine. This heat is removed by injecting a dose of liquid nitrogen into the cold cavity. The amount of heat that is taken away from the cold part of the engine was determined by formula:

$$Q_o = G(h_c - h_o),$$

where G – is the flow rate of nitrogen supplied to the engine cylinder; h_c – the enthalpy of nitrogen in the cold cavity of the engine; h_o – is the enthalpy of nitrogen, which is supplied by a liquid nitrogen pump from a container with liquid nitrogen. In the calculation, it assumed that liquid nitrogen adiabatically compressed by the pump to the pressure of 40 bars and fed into the cold cavity.

It is obvious that the amount of heat that removed by liquid nitrogen depends strongly on the temperature in the cold cavity of the engine. The higher nitrogen temperature in the cold cavity the more heat taken away with dose of

nitrogen injected. Therefore, the temperature in the cold cavity of the engine selected in thus the overall thermal balance of the engine is fulfilling. This value of the temperature in the cold cavity of engine was equal to 130 K.

In Figure 12 showed the calculated pressure-volume diagram of the proposed Stirling engine. This diagram also shows the areas where nitrogen injected and discharged.

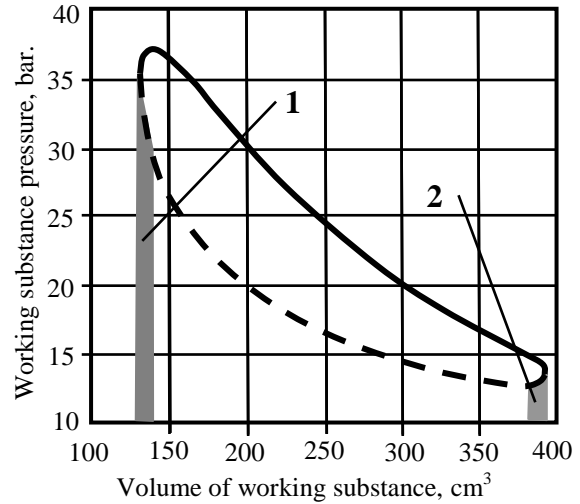

Figure 12 – Calculated pressure-volume diagram of the engine with the open Stirling cycle. 1 – nitrogen inlet; 2 – release of nitrogen.

Further, the efficiency of the regenerative heat exchanger evaluated.

In the working Stirling machine there is the changing a volumes of the warm and cold cavities and a pressure changing in these cavities. Therefore the instantaneous value and the sign of the flow of nitrogen through the regenerative heat exchanger was defined as the difference between changes within gas masses in the warm and cold cavities of the engine when the shaft is rotated by 2 angular degree.

Further, knowing the pressure and temperature of the gas at the inlet and outlet of the heat exchanger, the enthalpies of nitrogen at the inlet and outlet of the regenerative heat exchanger were determined. Knowing the mass flow rate of nitrogen in each of the positions, it is possible to determine the amount of heat that is supplied or diverted from the thermal elements of the regenerative heat exchanger when the shaft is rotated by the next 2 angular degrees.

In Fig. 13 shows the calculated graphs of the heat load of regenerative heat exchanger per revolution of the machine shaft. It can be see that the heat that accumulates in the packed bed of the regenerative heat exchanger in the cooling period is not enough to heat gas in the heating period. Therefore, the gas leaving the regenerative heat exchanger must warm to the temperature of the warm cavity, taking heat from the environment.

Such heat transfer features in the regenerative heat exchanger of the Stirling machine operating on an open cycle can be easily explained. Over injecting a doze of nitrogen into the cold cavity, the expenditure of nitrogen in the heating period is greater than its flow rate in the cooling period of regenerative heat exchanger.

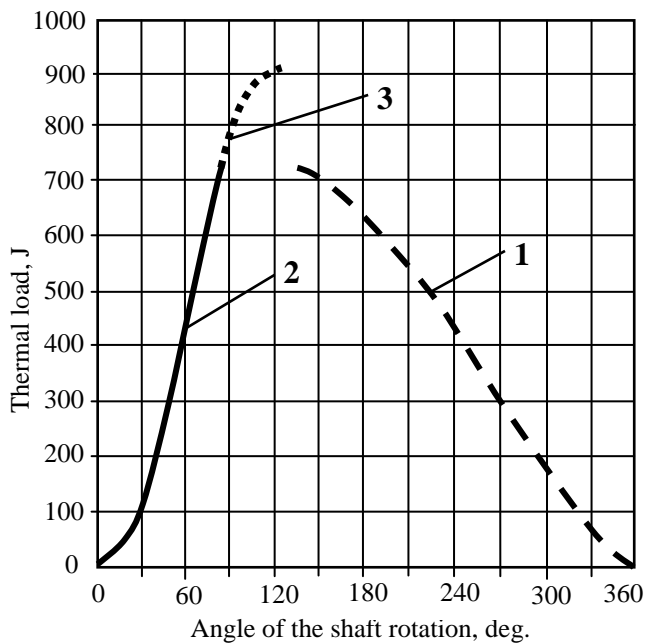

Figure 13 – Thermal load of the packed bed of regenerative heat exchanger for one revolution of the shaft.

1 – heating period; 2 – cooling period;
3 – heat supply from environment.

This ratio of the flow heat capacities during the heating and cooling periods of the regenerative heat exchanger is favorable for the Stirling engine. Insufficient nitrogen heating is compensated by the supply of heat from the environment. From the thermodynamic point of view, this is much better than compensating of the losses from the imperfection of heat transfer by a part of the useful cooling capacity, as is the case, in cryorefrigerators operating the Stirling cycle.

The described mathematical model of the open-cycle Stirling engine made it possible to optimize it in order to obtain the maximum efficiency of converting the exergy of liquid nitrogen into mechanical work. As a result of optimization the cold cavity temperature and amount of nitrogen supply, the following values of these parameters obtained. The optimal temperature of the cold cavity is equal to 130 K. The optimum proportion of injected nitrogen is 7.8% of the amount of nitrogen already in the cylinder. With these parameters, the engine produces 1.81 kW at 600 RPM. The flow rate of nitrogen in the optimum operating mode is 25 kg/h. At the same time, this engine can turn to work 39.5% of the exergy accumulated in liquid nitrogen (the minimum work of nitrogen liquefaction). To the warm part of the engine 5.1 kW of heat must supply.

Since nitrogen is released from the engine at a temperature of 250 K and a pressure of 12 bar, the heating of this nitrogen to 273 K and the expansion in a two-stage machine with an adiabatic efficiency of 75% makes it possible to obtain additional 0.82 kW of mechanical energy.

In sum, the energy produced by the Stirling engine and the expansion machine is 2.63 kW-h, which is 57.5% of the minimum liquefaction work of 25 kg of nitrogen.

To accelerate a small car at a speed of 55 km/h, requires an engine power of about 5 kW (data for LN2000

[5]). If the described Stirling engine, used in combination with an expansion machine to drive such a cryomobile, then at the speed of 55 km/h consumption of liquid nitrogen will be 1.1 l/km. Consequently, 200 liters of liquid nitrogen will suffice for to travel more than 180 km, while a full charge of a 300-kilogram weight of battery is sufficient to range for 160 km for the electric car Nissan Leaf.

Conclusions

The use of liquid nitrogen or liquid air as an intermediate energy carrier does not require use of scarce materials, and investments necessary to create appropriate infrastructure will be less than using other types of intermediate energy carriers.

As a result of the thermodynamic analysis of engines operating on liquid nitrogen, it shown that liquid nitrogen as an intermediate energy carrier is in no way inferior to existing batteries of electric power, in the event that a method for efficient extraction of energy from liquid nitrogen will be found.

The open Stirling cycle is proposed and the device for its realization described. Mathematical modeling of this device showed that the open Stirling cycle theoretically allows converting more than 50% of the exergy of liquid nitrogen into mechanical work.

When using the proposed Stirling engine for driving a cryomobile having mass up to 1500 kg with speed of 55 km/h., the consumption of liquid nitrogen will be 1.1 L/km. Consequently, 200 liters of liquid nitrogen will suffice for to travel more than 180 km, while a full charge of a 300-kilogram weight of battery is sufficient to range for 160 km for electric car Nissan Leaf.

References

- HITEC (Electronic source). Date of access 03.06.2017. Access mode: https://hightech.fm/2017/01/09/germany_renewables.
- Rabinowitz M. (2000) Power Systems of the Future. *IEEE Power Engineering Review*, 20 (3), 10-29.
- Chan C.C. (2007) The state of the art of electric, hybrid, and fuel cell vehicles. *Proceedings of the IEEE*, 95 (4), 704-718.
- Liquid Air (Electr. source). Date of access 03.06.2017. Access mode: https://en.wikipedia.org/wiki/Liquid_Air
- Peter D.Vitt (1997) (Electronic source). Date of access 03.06.2017. Access mode: www.dtic.mil/cgi-bin/GetTRDoc?AD=ADA350829
- Yogesh K. J. (2016) Cryogenic Liquid Nitrogen Vehicles (ZEV'S). *International Journal of Scientific and Research Publications*, 6 (9), 562-566.
- Ordonez C.A., Plummer M.C. (1997) Cold Thermal Storage and Cryogenic Heat Engines for Energy Storage Applications. *Energy Sources*, 19 (4), 389-396.
- Ordonez C.A. (2000) Liquid nitrogen fueled, closed Brayton cycle cryogenic heat engine. *Energy Convers. Manage*, 41(4), 331-341.
- Haisheng Ch., Yulong D., et al. (2011) Air fuelled zero emission road transportation: a comparative study. *Appl Energy*, 88 (1), 337-342.
- Dearman. A Technical Introduction. (Electronic

source). Date of access 03.06.2017. Access mode: <http://dearman.co.uk/wp-content/uploads/2016/05/Dearman-A-Technical-Introduction-For-Web-1.pdf>

11. **Isshiki N, Kojima H, Ushiyama I, Isshiki S.** (1999) Proposal and basic experiments of super stirling engines. *SAE Technical Paper*, v.1, p. 2502.

12. **Isshiki N, Kojima H, Ushiyama I, Isshiki S.** (2000) Report on the developments of steam super Stirling engine. *Energy Conversion Engineering Conference and Exhibit, (IECEC) 35th Intersociety: IEEE; 2000*, 111-119.

13. **Lin Ch.H, Lai G.J. Kobayashi Y., Matsuo M., Chiu M.Ch.** (2014) An Isothermal Steam Expander for an Industrial Steam Supplying System. *Hindawi Publishing Corporation Mathematical Problems in Engineering*. – Vol. 2015, 6 p. Article ID 794210, <http://dx.doi.org/10.1155/2015/794210>

14. **Weiqing X., Jia W., Maolin C., Yan S.** (2015) Liquid air fueled open–closed cycle Stirling engine. *Energy Conversion and Management*, 94, 210–220.

15. (Electronic source). Date of access 03.06.2017. https://www.ohio.edu/.../stirling/engines/NASA_MTI1986.pdf

Received 07 June 2017
Approved 08 September 2017
Available in Internet 30 October 2017