

UDC 536.24:641.565.4

## INVESTIGATION AND DEVELOPMENT OF AN INNOVATIVE HIGH ENERGY EFFICIENCY PIZZA BAKING OVEN DESIGN

<https://doi.org/10.15673/fst.v20i2.3460>

R.V. Myronov<sup>1</sup>  
L. Vesper<sup>2</sup>

<sup>1</sup>Inventor, restaurateur with 17 years of professional experience

<sup>2</sup>Information and Research Center “Ukrainian Intelligence”, Director

### Correspondence:

L. Vesper  
E-mail: vesper063@gmail.com

### Cite as Vancouver style citation

Myronov R.V., Vesper L. Investigation and development of an innovative high energy efficiency pizza baking oven design / Food Science and Technology. 2026;20(2):167-173. <https://doi.org/10.15673/fst.v20i2.3460>

### Цитування згідно ДСТУ 8302:2015

Myronov R.V., Vesper L. Investigation and development of an innovative high energy efficiency pizza baking oven design // Food Science and Technology. 2026. Vol. 20, Issue 2. P. 167-173 <https://doi.org/10.15673/fst.v20i2.3460>

Copyright © 2026 by author and the journal

“Food Science and Technology”.

This work is licensed under the Creative Commons Attribution International License (CC BY).

<http://creativecommons.org/licenses/by/4.0>



**Abstract.** This comprehensive scientific study investigates the development, technical implementation, and empirical evaluation of an advanced integrated thermo-aerodynamic recirculation method designed for high-efficiency hybrid pizza ovens utilizing a combination of wood and gas fuel sources. The engineered system introduces an innovative structural configuration featuring a dual-dome architecture integrated with a recuperative air gap, a uniquely structured stator-type guide vane assembly designed to generate counter-rotating vortex flows, and passive aerodynamic gates specifically calibrated to stabilize internal thermal environments against external wind disturbances. The research methodology encompasses a detailed multi-phase thermodynamic analysis, numerical simulations of coupled convective-radiative heat transfer mechanisms, and field experiments aimed at evaluating thermal response velocities and fuel consumption rates. The experimental results demonstrate a significant reduction in start-up intervals, with the system reaching its optimal operating temperature of five hundred degrees Celsius within twenty to thirty minutes, while maintaining exceptional spatial temperature uniformity within ten degrees Celsius. This precise thermal control reduces the total required baking duration to sixty seconds per unit, fulfilling the strict traditional speciality guaranteed standards established for authentic wood-fired artisanal pizza production. The subsequent economic analysis validates that the recirculation design substantially enhances overall energy efficiency and reduces baseline fuel consumption compared to standard commercial configurations. The findings confirm that the integration of thermo-aerodynamic recirculation loops offers a highly viable engineering strategy for enhancing performance in commercial catering applications, restaurant operations, and small-scale specialized production lines, providing a practical foundation for scaling energy-efficient thermal processing systems.

**Keywords:** pizza oven innovation; hybrid pizza oven; pizza baking; wood fired oven; heat transfer; high temperature baking; energy efficiency; thermal regime; sensory quality; consumer behavior; technological food innovation; artisanal pizza; wood fired pizza; premium pizza segment.

### Introduction. Formulation of the problem

The modern food industry encompasses both food products and the technological processes that enable their production. Pizza is a product shaped by complex technological and market dynamics, where the final quality is determined not only by the recipe but also by the baking technology.

Over the past five years (2021–2025), the global pizza market has demonstrated stable growth of +5–6% CAGR (Compound Annual Growth Rate) [1], along with explosive expansion in the *artisan / wood-fired / premium pizza* segment [2,3]. The steadily increasing demand in these segments is reshaping the B2B market: demand for wood-fired and hybrid ovens is rising and stabilizing. Importantly, wood-fired ovens have become a marker of product quality, even within the hybrid-oven segment. As a result, production standards for pizza are increasing, including TSG certification [4], the rapid development of local pizzerias and franchises, and

consequently, growing demand for the manufacturing of wood-fired and hybrid ovens.

The baking process is one of the most critical stages in the production of food products, particularly pizza, where the temperature regime directly affects the quality of the final product. Modern foodservice enterprises require equipment that ensures uniform heat distribution, rapid heating, and minimal energy consumption [5,6,7].

Traditional pizza ovens (wood-fired, gas, electric) can reach temperatures of 400–500°C, but they have several disadvantages, including low thermal efficiency (15–25%), uneven temperature distribution, long heating times, and significant heat losses. These factors reduce productivity and lead to inconsistent product quality [8,9,10]. Modular ovens that combine barbecue and open-fire functions also exhibit low energy efficiency and high sensitivity to wind gusts, which disrupt draft and cause temperature fluctuations. Gas

ovens provide precise temperature control but do not produce the characteristic wood-fired aroma and often overdry the pizza surface due to intense convective airflow.

Thus, the challenge remains to combine:

- high heating rate,
- uniform temperature distribution,
- energy efficiency,
- thermal stability,
- and the sensory authenticity of wood-fired

pizza.

This study substantiates the feasibility of implementing the thermo-aerodynamic recirculation method in oven manufacturing. An innovative oven design is proposed that eliminates the drawbacks of existing solutions through:

- a dual-dome structure with a recuperative gap,
- stator-type guide vanes that generate counter-rotating vortex flows,
- aerodynamic shutters that block reverse draft,
- a two-stage heating cycle (gas → pyrolysis → wood),
- intensification of radiative and convective heat transfer.

The proposed integrated method increases heat-flux density by optimizing the convective and radiative components of heat transfer, enabling a high-temperature baking regime (up to 500°C) with a reduced baking time of 60 seconds without compromising product quality.

It has been demonstrated that the implementation of this technology improves energy efficiency, stabilizes the temperature regime, enhances product consistency, and optimizes production processes [11].

#### Analysis of recent research and publications

From a marketing perspective, the use of wood-fired and hybrid ovens creates additional consumer value, increases customer trust, and provides competitive advantages in the artisanal, wood-fired, premium, and fast-casual segments [12,13,14,15].

According to Statista Research Department, Fig. 1, the artisanal and wood-fired pizza segment is showing higher growth rates (~8–10% CAGR) compared to the global pizza market (5–6% CAGR) [3,4,13]. This structural shift towards premiumization and increased consumer value is generating demand for wood-fired ovens as a separate market trend.

According to Euromonitor and industry reports [3,4,10,13], the most dynamic growth is observed in Asian markets, where wood-fired/artisan pizza is gaining a strong foothold in the luxury segment, accounting for 5–10% of the market and growing rapidly in CAGR terms. According to Statista [15], in the United States—where the pizza market exceeds \$45 billion annually—wood-fired pizza has traditionally been positioned as a premium niche product. The

steadily increasing demand has led to the emergence of a new market segment: wood-fired pizza as a mass-market product.

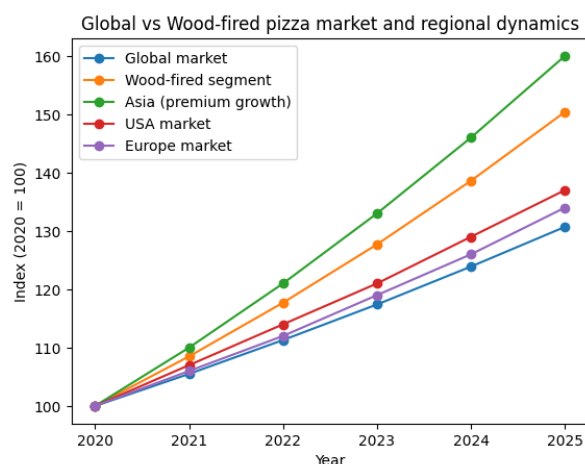

**Fig. 1. Dynamics of the global pizza market, the wood-fired/artisanal pizza segment, and regional markets (Asia, the USA, and Europe)**

In Europe, the birthplace of pizza standards, the market structure is also undergoing transformation. Over the past four years, the markets of Italy, France, Spain, and Germany have shown rapid growth in the premium casual dining segment. The “artisan pizza” category, including “wood-fired pizza,” has grown by +6–8% annually in major European cities, and up to 30–40% of newly opened pizzerias position themselves as “artisan, wood-fired pizza” establishments [11,16].

Due to the dynamic reconfiguration of the pizza market toward higher quality and intensified production, the technological sector is also undergoing transformation [17,18]. New methods and technological innovations that increase production efficiency while maintaining quality standards are attracting significant interest. The use of high-temperature baking regimes (500°C, 60 seconds) aligns with current market demands for rapid service and preservation of the product’s organoleptic characteristics [5,7,10,11,19,20].

#### Research materials and methods

The aim of this study is to substantiate and experimentally verify the effectiveness of an integrated thermo-aerodynamic recirculation method for high-efficiency pizza baking ovens, including its impact on thermal performance, temperature stability, and energy efficiency.

The study was conducted using an experimental prototype of a hybrid wood-fired/gas pizza oven developed by the author based on an integrated thermo-aerodynamic recirculation method.

**To achieve the stated aim, the following objectives were accomplished:**

- a conceptual design of a hybrid oven based on an integrated thermo-aerodynamic recirculation method was developed;
- existing pizza oven technologies were analyzed to identify key limitations;
- the thermo-aerodynamic configuration of the oven, including vortex flow formation and heat recirculation mechanisms, was investigated;
- the temperature operating regime and heating dynamics were experimentally studied;
- the uniformity of temperature distribution within the baking chamber was determined;
- the energy efficiency and heat transfer performance of the system were evaluated.

### Results of the research and their discussion

The innovative hybrid wood–gas oven features a multilayer, aerodynamically optimized structure that ensures intensive heat transfer, temperature stability, and high energy efficiency. Its operation is based on the combined action of radiative, convective, and recirculating heat transfer.

The oven structure was constructed using refractory ceramic materials with high heat resistance and thermal capacity (industrial-grade refractory components, EU standard production). The inner dome and hearth were made of dense refractory material, while the outer dome incorporated heat-insulating layers to reduce thermal losses.

Hardwood fuel (oak and beech, moisture content 10–15%) was used as the primary solid fuel during the baking stage. A gas burner system (propane–butane mixture, standard commercial supply) was applied for the initial heating phase.

Temperature measurements were performed using a high precision thermocouple (type K) installed inside the baking chamber.

The main components include:

#### 1. Double Dome with Recuperative Gap

Inner dome (7) — made of refractory material, forms the baking chamber and accumulates heat.

Outer dome (8) — thermally insulated, minimizes heat losses.

Recuperative gap (9) between the domes enables the circulation and reuse of hot gases, increasing overall efficiency.

#### 2. Stator Type Support Vanes (10)

Positioned between the domes and forming windows (11) for the passage of hot gases.

Designed as stator vanes:

- the upper section (14) induces clockwise rotation,
- the lower section (16) induces counter clockwise rotation.

These create counter rotating vortex flows that:

- intensify mixing of hot gases, The figure 4 shows how the recessed pockets of the aerodynamic shutters 18 prevent wind penetration, reducing the intensity of the downward convection flow 20 by at least two times.

As the experiment has shown, after the second level 26, the intensity of the flow 20 decreases by 5 or more times, ensuring heat locking inside the working chamber 4 without the use of mechanical dampers.

- ensure uniform heating of the floor and dome,
- stabilize the temperature regime.

#### 3. Baking Chamber and Base

Baking chamber (4) — the primary thermal processing zone.

Floor (5) — a high mass heat accumulating surface that ensures uniform baking.

Base (1) — structural support for the entire oven.

#### 4. Chimney and Aerodynamic Shutters

Chimney (2) equipped with aerodynamic shutters (18).

The shutters have two levels (25, 26) and serve to:

- reduce resistance during heating,
- block reverse draft,
- protect against wind gusts,
- retain heat inside the chamber.

#### 5. Gas Burner (21)

Used during the initial heating stage.

Produces a flame jet (23) directed into the recuperative gap.

Enables rapid heating to 300°C and initiates wood pyrolysis.

#### 6. Temperature Control

Thermocouple (24) provides real time monitoring of the temperature regime.

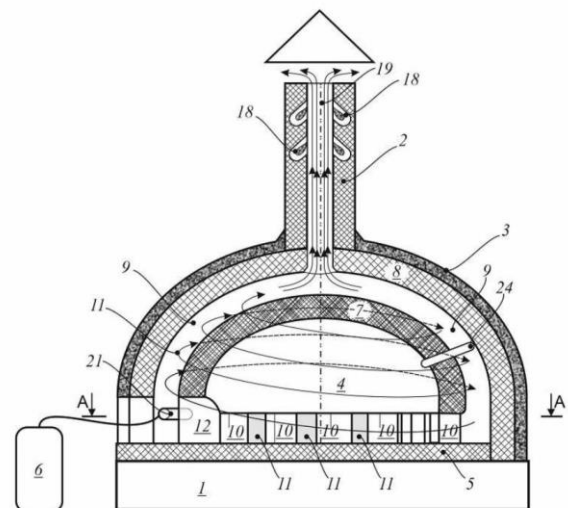
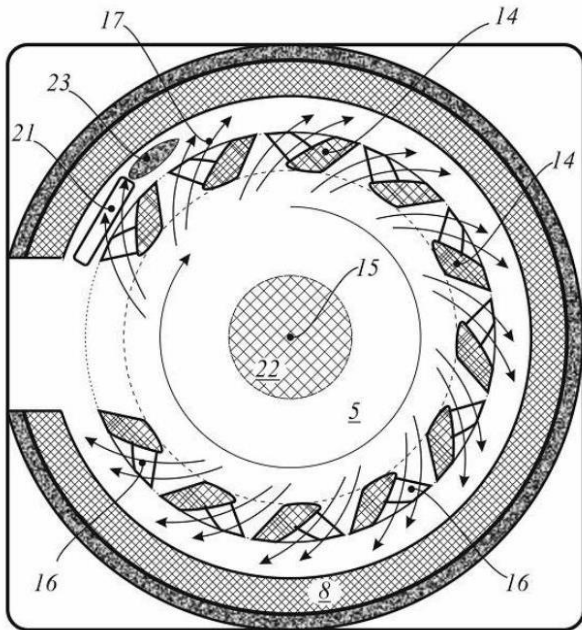

Fig. 2. Structure of the hybrid wood–gas oven

The figure 2 presents a sectional schematic of the dome-type oven, illustrating the internal chambers, gas circulation paths, and heat-transfer zones. It shows how the structural elements of the dome, base, and exhaust system interact to guide airflow and maintain thermal stability during operation.

The figure 3 illustrates the mechanism of simultaneous counter-rotating gas flows. This aerodynamic effect enhances hot-gas mixing, ensures uniform heating of the floor and dome, and stabilizes the overall thermal regime.



**Fig. 3. Cross-sectional schematic of the vortex-inducing stator-rotor assembly used to generate controlled gas circulation in the oven**

The figure 4 shows how the recessed pockets of the aerodynamic shutters 18 prevent wind penetration, reducing the intensity of the downward convection flow 20 by at least two times. As the experiment has shown, after the second level 26, the intensity of the flow 20 decreases by 5 or more times, ensuring heat locking inside the working chamber 4 without the use of mechanical dampers.

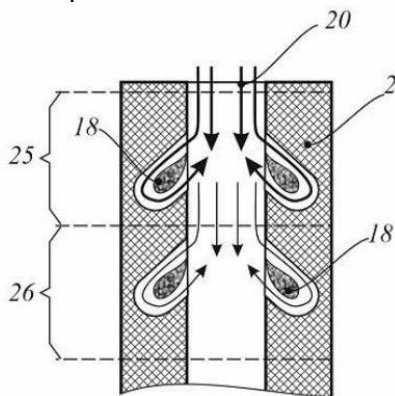

**Fig. 4. Passive aerodynamic shutters for thermal stabilization and wind protection**

The research methodology was structured according to the objectives of the study and included the following stages:

1. Analysis of existing technologies

A comparative analysis of conventional pizza oven designs (traditional wood-fired Pompeian ovens, gas-assisted ovens, and modular baking systems) was performed to identify key technological limitations, including thermal inefficiency, long heating time, and non-uniform heat distribution.

2. Design and construction of the experimental oven

An innovative hybrid oven based on an integrated thermo-aerodynamic recirculation method was designed and constructed. The design included a dual-dome configuration consisting of an inner refractory dome (baking chamber) and an outer dome forming a recuperative heat exchange space.

3. Thermo-aerodynamic configuration

The internal structure of the oven was optimized to generate controlled vortex airflow using stator-type guide elements. These elements created counter-rotating flows of combustion gases, ensuring intensive mixing and uniform temperature distribution within the chamber.

$$q = h(T_{air} - T_{surface}) + \epsilon\sigma(T_{wall}^4 - T_{surface}^4)$$

where:

$q$  — total heat flux ( $W/m^2$ );

$h$  — convective heat transfer coefficient ( $W/(m^2 \cdot K)$ );

$T_{air}$  — air temperature in the oven (K);

$T_{surface}$  — product surface temperature (K);

$\epsilon$  — emissivity;

$\sigma$  — Stefan-Boltzmann constant ( $\sigma = 5.67 \times 10^{-8} W/(m^2 \cdot K^4)$ )

$T_{wall}$  — oven wall temperature (K).

The difference ( $T_{air} - T_{surface}$ ) determines the convective heat flux.

At high temperatures ( $\sim 500^\circ C$ ), radiative heat transfer dominates, significantly increasing heating intensity and reducing baking time.

Thus, the heat flux reaching the product surface is determined by the combined contribution of convective and radiative components. The convective component depends on the temperature difference between the oven air and the product surface, whereas the radiative component is governed by the temperature of the oven walls and follows the Stefan-Boltzmann law. At temperatures around  $500^\circ C$ , radiative heat transfer becomes dominant, resulting in a sharp increase in heating intensity and enabling the baking time to be reduced to 60 s.

4. Heating regime investigation

The oven operation was studied under a two-stage heating process:

– Stage 1: rapid heating using a gas burner to reach the target temperature;

– Stage 2: wood combustion under preheated conditions.

The temperature regime was analyzed under steady-state conditions at operating temperatures up to 500°C.

**Temperature distribution analysis**

Temperature fields within the baking chamber were evaluated using a multi-point measurement system based on K-type thermocouples. A total of three контрольні точки (thermocouples) were installed in representative zones of the chamber, as shown in Fig.6.

The measurement points were distributed as follows:

- the upper zone of the dome (hot gas region),
- the mid-height wall region (recirculating flow zone),
- the lower zone near the hearth (product-level region).

This spatial arrangement allows capturing vertical and circumferential temperature gradients within the chamber.

The uniformity of heat distribution was assessed based on spatial temperature variations between these points under steady-state operating conditions.

**Heating rate determination.**

The heating rate was determined by measuring the time required to reach the operating temperature from ambient conditions.

**7. Energy efficiency evaluation**

Energy efficiency was assessed based on fuel consumption and thermal performance indicators, including heat retention, reduction of thermal losses, and stability of the temperature regime.

$$\eta = \frac{Q_{useful}}{Q_{input}}$$

where:

$\eta$  – efficiency (thermal efficiency)

$Q_{useful}$  – useful heat (output energy)

$Q_{input}$  – input energy

Experimental validation

The performance of the developed oven was experimentally verified under real operating conditions, including pizza baking at temperatures up to 500°C. The evaluation criteria included heating time, temperature stability, and baking quality.

The studies were conducted in two stages:

- heating stage (0–30 min);
- temperature stabilization stage (30–60 min).

The applied methodology integrates principles of thermodynamics, aerodynamics, and heat transfer, ensuring reproducibility of the experimental procedure and enabling further optimization of high-efficiency baking systems.

To substantiate the claim regarding improved energy efficiency, a comparative analysis of fuel consumption and thermal performance of different oven types was performed based on literature data.

Traditional wood-fired pizza ovens (Italian dome furnaces) are characterized by significant heat losses due to their open structure and limited control of airflow, which affects overall energy efficiency [14]. These systems require continuous fuel input to maintain high baking temperatures (450–500°C), particularly under intensive operating conditions.

**Explanation of Thermocouple Positions (Red Circles)**

The red circles indicate the locations of thermocouples used for temperature field analysis inside the oven chamber.

**TC1 (Upper zone):** located near the upper left part of the dome to capture the high-temperature region of the hot gas layer.

**TC2 (Right wall zone):** positioned at the mid-height of the right side wall to monitor the temperature of the cavity wall and recirculating gas.

**TC3 (Lower zone):** placed near the lower left part of the chamber to evaluate the cooler region close to the hearth and ensure uniformity of the temperature distribution.

These measurement points provide representative data for assessing the temperature uniformity within the oven chamber and the effectiveness of the thermoaerodynamic recirculation system.

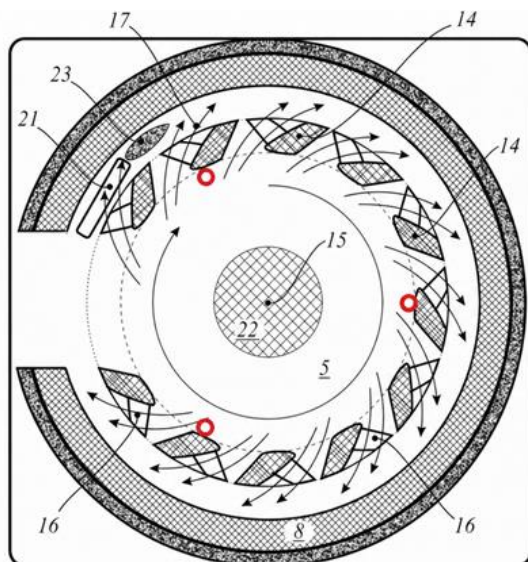

Sensor ID	Location	Position	Purpose
TC1	Upper zone	Upper left part of the dome (near item 17)	Measure temperature in the upper hot gas layer; evaluate maximum temperature.
TC2	Right wall zone	Right side wall at mid-height (near item 14)	Monitor wall and gas temperature on the right side; assess recirculation effect.
TC3	Lower zone	Lower left part of the chamber (near item 16)	Measure lower temperature region near the hearth; verify temperature uniformity.

**Fig. 6. Explanation of thermocouple**

In contrast, electric high-temperature pizza ovens demonstrate more stable thermal control but often require significant electrical energy input. As reported in Thermal analysis of a high-temperature electric pizza oven, energy consumption in electric systems may reach 6–10 kWh per hour under high-temperature baking conditions, with lower radiative heat contribution compared to wood-fired systems. [12].

The proposed integrated thermo-aerodynamic recirculation method aims to reduce these inefficiencies by enhancing heat flux density and improving internal airflow dynamics. Based on experimental observations and engineering estimates, the optimized system can reduce fuel consumption to approximately 2.5–3.0 kg of firewood per hour under continuous operation at 450–500°C, corresponding to an estimated 0.03–0.04 kg of fuel per pizza (2\*35 cm diameter, ~60 s baking time).

This indicates a potential reduction in specific energy consumption of approximately 20-30% compared to other ovens, primarily due to improved heat retention, recirculation of hot gases, and more efficient utilization of radiative heat transfer.

### Conclusion

A comprehensive analysis of the modern pizza market, its trends and tendencies, as well as existing technologies and methods in the designs of pizza ovens, made it possible to substantiate the feasibility of implementing a technological innovation in pizza production - “Integrated method of thermo-aerodynamic recirculation for high-efficiency ovens”. Based on practical experience in doing business, marketing research and the results of a scientific and technical experiment (model oven design), the author of the invention, R. V. Mironov, developed an improved methodology for pizza production. The proposed methodology integrates thermodynamics, aerodynamics, and heat-transfer optimization within the oven, significantly increasing production efficiency, reducing operational costs, and meeting modern consumer expectations. This methodology is registered

with the Ukrainian National Office of Intellectual Property and Innovations (UKRNOIVI) under the title “Integrated thermo-aerodynamic recirculation method for high-efficiency ovens,” application number u202601606.

An innovative hybrid wood–gas oven with a double-dome structure and recuperative gap was developed and experimentally evaluated, demonstrating improved heat transfer and higher thermal efficiency compared with conventional designs.

The use of stator-type vanes generated counter-rotating vortex flows, which ensured uniform temperature distribution within the baking chamber and reduced thermal gradients across the floor and inner dome.

The two-stage heating mode (gas pre-heating followed by wood-fired pyrolysis) significantly reduced the time required to reach high-temperature baking conditions (450–500°C) and stabilized the thermal field during operation.

Aerodynamic chimney shutters effectively minimized heat losses and prevented reverse draft, contributing to stable oven performance under varying external conditions.

Temperature measurements confirmed enhanced energy efficiency due to heat recuperation and optimized circulation of hot gases within the dome system.

The obtained results demonstrate the feasibility of achieving high-temperature baking within 60 seconds without compromising product quality, confirming the technological effectiveness of the proposed oven design for food processing applications.

The implementation of the proposed method can be adapted both for ovens with different dimensions of the working chamber, and for modifications for different types of products used in the restaurant business. Thus, the innovation forms the basis for increasing the productivity of production, reducing operating costs and ensuring stable quality of finished products.

### References:

1. Euromonitor International. Available from: <https://www.euromonitor.com> [cited 2026 Feb 02].
2. Grand View Research. Pizza Market Report. Available from: <https://www.grandviewresearch.com/industry-analysis/pizza-market> [cited 2026 Feb 18].
3. Statista Research Department. Pizza market worldwide – statistics & facts [Internet]. 2025 Dec 17. Available from: <https://www.statista.com/topics/13782/pizza-market-worldwide/> [cited 2026 Apr 18].
4. European Commission. Commission Regulation (EU) No. 97/2010. Entering a Name in the Register of Traditional Specialities Guaranteed [Pizza Napoletana (TSG)]. Off J Eur Union. 2010;34. Available from: <https://eur-lex.europa.eu/legal-content/EN/TXT/?uri=CELEX:32010R0097> [cited 2026 Mar 15].
5. Le-Bail A, Monteau JY, Margerie F, Lucas T, Chargelegue A, Reverdy Y. Modeling heat and mass transfer in a pizza baking process. *J Food Eng.* 2011;107(3–4):493–503.
6. Sahin S, Sumnu SG. *Advances in baking technologies*. Boca Raton: CRC Press; 2009.
7. Zaroni B, Peri C, Bruno D. Modelling of browning kinetics of bread crust during baking. *LWT Food Sci Technol.* 2012;45(1):41–47.
8. Falciano A, Masi P, Moresi M. Unlocking the secrets of Neapolitan pizza: A concise review of wood-fired, electric, and gas pizza ovens. *J Food Sci.* 2024;89:6966–6984. Available from: <https://doi.org/10.1111/1750-3841.17417>
9. Ciarmiello M, Morrone B. Why not using electric ovens for Neapolitan pizzas? A thermal analysis of a high-temperature electric pizza oven. *Energy Procedia.* 2016;101:1010–1017. Available from: <https://doi.org/10.1016/j.egypro.2016.11.128>
10. Aguilera JM. Relating food engineering to cooking and gastronomy. *Compr Rev Food Sci Food Saf.* 2018;17:1021–1039. Available from: <https://doi.org/10.1111/1541-4337.12361>

11. De Pilli T. Application of fuzzy logic system for the pizza production processing optimisation. *J Food Eng.* 2022;319:110906. Available from: <https://doi.org/10.1016/j.jfoodeng.2021.110906>
12. Mansour Y, Rouaud O, Slim R, Rahmé P. Thermal characterization of a high-temperature industrial bread-baking oven: A comprehensive experimental and numerical study. *Appl Therm Eng.* 2024;236:121467. Available from: <https://doi.org/10.1016/j.applthermaleng.2023.121467>
13. Stazio M. Verace glocal pizza: Localized globalism and globalized localism in the Neapolitan artisan pizza. *Food Cult Soc.* 2021;24(3):406–430. Available from: <https://doi.org/10.1080/15528014.2021.1884400>
14. Falciano A, Masi P, Moresi M. Performance characterization of a traditional wood-fired pizza oven. *J Food Sci.* 2022;87:4107–4118. Available from: <https://doi.org/10.1111/1750-3841.16268>
15. Statista Research Department. Pizza consumption in the U.S. [Internet]. 2023. Available from: <https://www.statista.com/statistics/1176505/pizza-restaurant-industry-market-size-us/> [cited 2026 Apr 18].
16. Fortune Business Insights. Pizza market size, share & COVID-19 impact analysis [Internet]. 2023. Available from: <https://www.fortunebusinessinsights.com/pizza-market-103688> [cited 2026 Apr 18].
17. Covino C, et al. Asparaginase enzyme reduces acrylamide levels in fried and wood-oven baked pizza base. *Food Chem Adv.* 2023;2:100206. Available from: <https://doi.org/10.1016/j.focha.2023.100206>
18. Li AZT, Walker CE. Cake baking in conventional, impingement and hybrid ovens. *J Food Sci.* 1996;61(1):188–191. Available from: <https://doi.org/10.1111/j.1365-2621.1996.tb14756.x>
19. Saini P, Pandey S, Goswami S, Dhar A, Mohamed ME, Powar S. Experimental and numerical investigation of a hybrid solar thermal-electric powered cooking oven. *Energy.* 2023;128188. Available from: <https://doi.org/10.1016/j.energy.2023.128188>
20. Du CJ, Barbin DF, Sun DW. Quality evaluation of pizzas. In: Sun DW, editor. *Computer vision technology in the food and beverage industries.* Academic Press; 2016. p. Chapter 19. Available from: <https://doi.org/10.1016/B978-0-12-802232-0.00019-0>

## ДОСЛІДЖЕННЯ ТА РОЗРОБКА ТА ІННОВАЦІЙНОЇ КОНСТРУКЦІЇ ПЕЧІ ДЛЯ ВИПІКАННЯ ПІЦИ З ПІДВИЩЕНОЮ ЕНЕРГОЕФЕКТИВНІСТЮ

**Р. В. Миронов**, <sup>1</sup>Винахідник, ресторатор з 17- річним досвідом  
*E-mail:* mironov.promo@gmail.com

**Л.Л. Веспер** директор  
 Інформаційно-дослідницький Центр «Український інтелект»,  
*E-mail:* vesper063@gmail.com

**Анотація** У статті представлено технологічну інновацію - «Інтегрований метод термоаеродинамічної рециркуляції для високоефективних печей», реалізовану в гібридній пічці, що працює на дровах та газі. Конструкція включає подвійний купол із рекуперативним проміжком, систему напрямних лопаток статора, що формують зустрічні вихрові потоки, та аеродинамічні затвори пасивної дії, які забезпечують стабільність температури та захист від поривів вітру. Проведено аналіз теплотехнічних характеристик, моделювання комбінованого конвективно-радіаційного теплообміну та експериментальні дослідження температурного режиму, швидкості нагріву, рівномірності температурного поля та оцінку витрат палива на основі інженерного підходу. Встановлено, що запропонована конструкція забезпечує швидкий вихід на температуру 500°C (20–30 хв), стабільність температури  $\pm 10^\circ\text{C}$  та скорочення тривалості випікання піци до 60 с. Економічний аналіз підтверджує підвищення енергоефективності та зниження витрат палива порівняно з традиційними печами. Результати підтверджують доцільність впровадження конструкції у ресторанному господарстві та малих виробничих цехах. Температурний режим печі відповідає вимогам стандартів TSG «Traditional Speciality Guaranteed» для виробництва піци на дровах. У статті обґрунтовано економічну ефективність запропонованої інновації та представлені експериментально підтвержені результати, що демонструють доцільність та ефективність розробленої конструкції печі в реальних умовах експлуатації.

**Ключові слова:** інноваційна модель печі для випікання, гібридна піч для випікання піци, дров'яна піч; передача тепла; високотемпературний режим випікання; енергетична ефективність; сенсорні характеристики; поведінка споживачів; інноваційні харчові технології; ремісничка піца; піца на дровах; піца преміального сегменту

**Received 28.01.2026**

**Revised 14.02.2026**

**Approved 28.04.2026**

**Available in Internet 14.05.2026**