

UDC [664.71-11:664.64.016]

INVESTIGATION OF THE BAKERY PROPERTIES OF WHOLEMEAL FLOUR OBTAINED FROM BLACK WHEAT

DOI: <http://dx.doi.org/10.15673/fst.v13i3.1474>

Article history

Received 22.02.2019
Reviewed 14.03.2019
Revised 18.05.2019
Approved 03.09.2019

Correspondence:

D. Zhygunov
E-mail: dimius75@gmail.com

Cite as Vancouver Citation Style

Zhygunov D, Khorengy N, Voloshenko O, Zhyhunova H. Investigation of the bakery properties of wholemeal flour obtained from black wheat. Food science and technology. 2019;13(3):26-35. DOI: <http://dx.doi.org/10.15673/fst.v13i3.1474>

Cite as State Standard of Ukraine 8302:2015

Investigation of the bakery properties of wholemeal flour obtained from black wheat / Zhygunov D. et al. // Food science and technology. 2019. Vol. 13, Issue 3. P. 27-35. DOI: <http://dx.doi.org/10.15673/fst.v13i3.1474>

Copyright © 2015 by author and the journal
"Food Science and Technology".

This work is licensed under the Creative Commons
Attribution International License (CC BY).
<http://creativecommons.org/licenses/by/4.0>



D. Zhygunov, Doctor of Technical Sciences, Associate Professor¹

N. Khorengy, Candidate of Technical Science,
Associate Professor¹

O. Voloshenko, Candidate of Technical Science, Associate
Professor¹

H. Zhyhunova, master²

¹Department of Technology of Grain Processing

²Department of Technology of Grain Storage
Odessa National Academy of Food Technologies
112, Kanatnaya Str., Odessa, Ukraine, 65039

Abstract. The article considers the end use of a new wheat variety with a high biological value, *Chornobrova*. It is shown that, for the nation's health, it is important to increase the nutritional value of flour by increasing the content of the main nutrients (proteins) and essential micronutrients, in particular, by biofortification of plants. In the biofortification area, scientists all over the world are actively working on the so-called "coloured," or pigmented, grain of barley, wheat, rice in order to increase its biological value and make it functional, health-improving food. Of the diversity of the new "colour-grained" varieties, the least studied is wheat, in particular, black (or black-grained) wheat. The purpose of the paper is to prove how practical it is to make whole grain wheat flour of high biological value from black wheat. In order to achieve this goal, the following tasks must be solved: determining the main technological and baking properties of black wheat of the *Chornobrova* variety and wholemeal flour made from it; studying the parameters of the test-baked bread from wholemeal flour with and without different additives. The study objects are wheat grain of the *Chornobrova* variety, wholemeal flour obtained from it, and model mixtures. The wheat grain was harvested in 2016, and stored for 12 months, with the following quality parameters: moisture content 12.6%; crude protein content 10.8%; crude ash content 1.53%; crude gluten content 23%; gluten quality group I, sedimentation 33 ml; grain unit weight 733 g/l; thousand-kernel weight 40 g; vitreousness 68%. The quality characteristics of the wholemeal flour obtained in a laboratory environment have been determined: the colour light brown, with dark speckles; the smell and taste typical of those of wheat flour; humidity 12.9%; crude gluten content 23.5%; gluten quality group I; gluten colour light brown; acidity 2.6°H; flour density: the residue on sieve 067–4%, and the undersize on sieve 38–60%. A series of experiments has allowed establishing that bakery products from *Chornobrova* are hardly worse than those made from traditional wheat flour: their humidity is by 2 % lower, acidity by 1.1°H higher, and porosity by 6.5% less than those of the control sample. The specific volume of the experimental sample is 14% less than that of the control, which is due to the low rheological properties of gluten of the *Chornobrova* variety. The only significant drawback of the bakery product is its specific colour – almost black. Adding a whitener in an amount of 0.015% to the recipe did not compensate for this fault, but adding an improving agent somewhat increased the porosity and specific volume of the bread. Thus, based on the research carried out, the article proves that it is only practical to produce wholemeal wheat flour, which is of high biological value. The basic technological and baking properties of wheat of the *Chornobrova* variety, and those of the wholemeal flour obtained from it in a laboratory environment have been determined. The test baking parameters of bread from wholemeal flour without and with the addition of various additives have been studied. It has been recommended to use it with the improving agent *Top Bake Ban Bread* (0.5%), or in a rye and wheat mixture, which will make it possible to improve not only the traditional colour of bread but also the properties of this product.

Keywords: biological value, black wheat, wholemeal flour, baking properties.

Introduction. Formulation of the problem

Since recently, the idea of “healthy diet” has been prevailing in the world. It makes manufacturers never stop expanding the range of their products, produce environmentally friendly, natural foods and products enriched with substances that prevent nutrition-dependent conditions [1]. When choosing a food product that needs enriching, along with biomedical and hygienic aspects (mass character and regularity of consumption, availability to all social groups, etc.), the technological factors are taken into account, too: whether the enriching supplements are physically, chemically, and organoleptically compatible with the product to be enriched, whether there is (or can be created) a simple and reliable enrichment technology that allows preserving the necessary nutrients [2]. Traditionally, in Ukraine, the leading role in daily mass consumption of food is that of bakery products. Their biological value is reduced because of the refined composition of the main component of the recipe, top-grade wheat flour. This is due to the fact that the processing cereals into flour is accompanied by significant losses of micronutrients – vitamins and minerals removed together with the bran and germs of grains. So, to improve the health of the nation, it is important to increase the nutritional value of flour by increasing the content of essential nutrients (proteins) and essential micronutrients (vitamins, minerals).

The problem of micronutrient deficiency is solved in a number of ways. An approach recognized worldwide is a modification of the technology: vitamins or their mixtures are added to raw materials used to make food (for example, bakery flour), or directly to foodstuffs (bread, cereals, baby food, dairy products). But nowadays, flour is fortified with vitamin preparations in volumes that are not enough to make up for the deficiency of nutrients. Another approach is based on biofortification and functional products based on vegetable raw materials.

Biofortification is improvement of the nutritional qualities of plants by developing optimum ways of their mineral nutrition (fertilizing the soil), by using traditional breeding methods, and by creating new plants using molecular genetic approaches. The implementation of this strategy is based on hybridization, chemical and radiation mutagenesis, selective breeding, methods of molecular genetics, as well as scientifically proved technologies. The essence of biofortification is changing the properties of the plant itself. This is the point where it differs from the fortification of food products, which involves deliberate introduction of additional micronutrients and vitamins into foods to improve their nutritional or biological value. The ultimate goal is to create plants with high levels of certain elements and compounds absorbed from the soil, and of those synthesized in the plant (vitamins, secondary metabolites). This is achieved by using traditional breeding methods or

genetic engineering. Besides, modern genetic engineering technologies allow synthesizing compounds that are unusual to plants and accumulating them in certain parts of plants, in order to give certain cultures new improved properties and ensure the nutritional value of the diet. Thus, biofortification is a new and promising approach to solve global nutrition problems [3].

In biofortification, a promising direction of plant breeding is that aimed at creating functional foods, in particular, at obtaining varieties with a high content of carotenoids and flavonoids [4-6].

Analysis of recent research and publications

Today, the State Register of Plant Varieties suitable for distribution in Ukraine includes more than 300 winter wheat varieties. The frost resistance of over 65% of them is increased or higher than average. Up to 30% are of average frost resistance and high tolerance of extreme environmental factors [7]. Most of the recommended winter wheat varieties produce grain that meets the quality requirements for strong wheat: 170 varieties (66%) and 78 varieties (30%). Their grain conforms the parameters of valuable wheat varieties.

In the sphere of biofortification, scientists all over the world are actively working on the so-called “coloured,” or pigmented grain of barley, wheat, rice in order to increase its biological value and make functional (health-improving) food products from them. The colour of grain is due to the presence and balance of pigments contained in the pericarp, seed coat, and aleurone layer [8-10].

Most rice varieties (*Oryza sativa*) grown industrially in many rice-growing countries have white pericarp. However, the caryopses (grains) of this crop can be black, brown, red, and purple. The red, brown, purple, or black colour of rice grains depends on the amount and balance of anthocyanins contained in different pericarp, seed coat, and aleurone layers. Most rice-growing countries, including the European ones, cultivate locally bred rice varieties with the coloured pericarp [11-14]. The grain of such varieties is suitable for therapeutic nutrition, since unpolished rice is rich in vitamins and minerals. Thus, red rice contains more iron and zinc in comparison with white rice, and rice with the purple or black pericarp is richer in such minor elements as magnesium, calcium, molybdenum, as well as vitamins B1, B6, and B12. This rice is highly valued for its nutritional and taste qualities. The red pigment of rice grain, proanthocyanidin, is a powerful antioxidant that reduces the risk of atherosclerotic plaques [15].

The investigation [16] of black, red, brown, and white rice grown in Camargue, France, showed that the main compounds in black rice are anthocyanins (3.5 mg/g), then flavones and flavonols (0.5 mg/g), and flavan-3-ols (0.3 mg/g). Significant amounts of γ -Oryzanols as well as low levels of carotenoids

(6.5 mg/g) were also found. Red rice showed a large amount of oligomeric procyanidins (0.2 mg/g), whereas flavones, flavonols, and anthocyanins constituted less than 9 %. Brown and white rice contained fewer phytochemicals in the form of flavones/flavonols (21–24 µg/g) together with carotenoid traces. Neither anthocyanins nor procyanidins were found in brown and white rice.

The selective breeding of pigmented grain cereals has also been involved barley. For example, the famous hull-less (“naked”) variety Granal-32 (variety L-32) has a black caryopsis [17]. The grain of this barley contains a higher level of biologically active substances: up to 14.6 % of protein; 5.06% of essential amino acids; the total content of the vitamins E, B1, B2, B3 82.31 mg/kg; and its anthocyanides content is 25 times higher compared to traditional covered grain. It has been established that flour of the L-32 variety can be used to make confectionery with higher taste qualities.

Besides red wheat, which is common throughout the world, crop breeders have bred blue, violet, purple, black, and white (white-kernelled) wheats. Blue wheat grain is recognized as a good source of bio-active compounds that are potentially health-improving: such as dietetic fibre, phenolines, tocopherols, and carotenoids [18]. Unlike red and white wheats, the ones coloured blue-violet, blue, and black contain natural anthocyanin compounds. An extract of the blue spring wheat variety Purendo 38 contained four basic anthocyanins, while in violet wheat, there were five. The anthocyanin that prevailed in violet wheat was cyaniding-3-glucoside, which was the second major anthocyanin in blue wheat. The dominant anthocyanin in blue wheat (about 41 % of the total anthocyanin content) is still structurally unrecognized. The thermostability of blue wheat anthocyanins becomes higher with an increase in the pH level from 1 to 5. The temperature rise from 65 to 95°C led to degradation of blue wheat anthocyanins.

Black wheat is high in crude protein compared to common wheats. It has been observed that the protein content in Chinese black wheat grain (17.71%) is higher than that in the control wheat samples, but proteins of black wheat have the lowest digestibility [19]. This wheat can be used to make baking flour, since its HMW-glu subunits are similar to those found in common wheat. The quality of proteins of black wheat should be improved by the technology of its growing to increase the strength of its gluten, which is weaker than that in common wheats. Black-violet and blue wheats also contain natural anthocyanins whereas red and white wheats do not [20].

Scientists have established that Chinese black wheat has the highest activity and the highest phenol content among the studied wheat samples [21]. Chinese black wheat can be considered to be a potential source of natural antioxidants because of its

high free radical oxidation ability and phenol content. However, the authors point out that more research is needed to study other phenolic compounds and to evaluate their contribution to antioxidant activity, which will allow understanding the nutraceutical value of the new black wheat genotype.

At the Selective Breeding and Genetics Institute (Odessa, Ukraine), O. Rybalko, D. Axelrud, and M. Litvinenko have created and presented the first Ukrainian black wheat variety, with an increased content of the highly soluble protein fraction, vitamins, and microelements, named *Chornobrova*. This variety has a new allele at the Gld 1B locus, which is due to the fact that wild relatives of wheat took part in its origin [22]. This is a detailed description of the variety: spike type – awned; maturity group – medium early; frost resistance – above the average; drought resistance – high; lodging resistance – above the average; resistance to shattering – high; disease resistance – medium; grain – valuable by its quality; grain colour – dark brown to black; endosperm consistency – hard. The grain, due to its high content of protein (14–15%), vitamins, and minor elements, is supposed to be used as food [23].

In the human body, anthocyanins of black wheat reveal the following properties: antioxidant; antispasmodic; adaptogenic; anti-inflammatory; stimulating; diuretic; bactericidal; anti-allergic; choleric; haemostatic; sedative; antiviral; estrogenic; anti-oedema. Considering that anthocyanins are not synthesized in the human body, it is important to consume at least 15 milligrams of the compounds a day to prevent functional disorders. For this purpose, the diet is enriched with “coloured” foods. The functions of anthocyanins are as follows: they activate metabolism at the cellular level; reduce capillary permeability; increase vascular elasticity (due to inhibition of hyaluronidase activity); strengthen the retina; normalize the intraocular pressure; potentiate collagen synthesis; stabilize phospholipids of cell membranes; prevent cholesterol plaques from sticking to the walls of blood vessels; improve night vision (by rhodopsin regeneration); protect the heart muscle from ischaemia (prevent the production of proteins that activate apoptosis of cardiac myocytes); lower blood pressure (relax blood vessels); prevent cataracts; improve the condition of connective tissues; inhibit the growth of malignant tumours (stimulate apoptosis of cancer cells); increase the antioxidant protection of the body; prevent damage to the DNA structure; reduce the negative effect of radiation and carcinogens on the body; accelerate recovery from respiratory diseases.

The research [24] is an investigation how the wheat variety, the type of processing, and the processing technology effect on antioxidant properties. Wholegrain and dark wheat flour significantly increased the total phenolic content, the total flavonoid content, and the antioxidant activity than high-grade flour. The results indicate that wholegrain wheat flour and dark wheat flour are good for human health.

Based on the review of literature, it can be concluded that to improve the nation's health, it is necessary to increase the nutritional value of baked goods by, first, using grain varieties with the "coloured" surface, and second, increasing the proportion of bakery products made from wholegrain (wholemeal) flour in the human diet. These products will be high in proteins, minerals and biologically active substances.

There is not enough information on the technological properties of wholemeal flour from coloured (black) wheat, and no information at all about using wholemeal black wheat flour, as it is or in the form of wheat and rye mixtures, to make bakery products, with or without the addition of baking improvers and whiteners. That is why, in our opinion, this study dedicated to these issues is topical.

The purpose of the work is to prove that producing whole wheat flour of high biological value from black wheat is practical.

To achieve this goal, it is necessary to solve the following **problems**:

1. To determine the main technological and baking properties of wheat *Chornobrova* and of wholegrain flour obtained from it;

2. To study the baking properties of wholegrain flour from *Chornobrova* wheat as a component of wheat and rye or rye and wheat flour mixtures.

3. To investigate the parameters of test baking of bread made from wholegrain flour, with and without different additives.

Research materials and methods

The research part of the work was carried out in a laboratory environment at the Department of Grain Processing Technology at ONAFT and in the testing laboratory of the SC *Agmintest* Control Union.

The object of research: the technological and baking properties of raw materials; the characteristics of test-baked bread made from wholegrain wheat flour and from wheat and rye or rye and wheat flour mixtures.

The subjects of research are black wheat grain of the *Chornobrova* variety, the wholemeal flour obtained from it, and model mixtures. The wheat grain was harvested in 2016, and stored for 12 months, with the following quality parameters: moisture content 12.6%; crude protein content 10.8%; crude ash content 1.53%; crude gluten content 23%; gluten quality group I, sedimentation 33 ml; grain unit weight 733 g/l; thousand-kernel weight 40 g; vitreousness 68%.

The chemical composition and the technological properties of the wheat grain of the *Chornobrova* variety were determined by standardized methods (Table 1).

Table 1 – Methods of determining the quality of grain, flour, and bread

Parameter	Standard or method
Smell and colour of grain	GOST 10967-90 Grain. Methods of determining odour and colour
Thousand-kernel weight	GOST 10842-89 Grain of cereal and legume crops and oilseeds. Method of determining the thousand-kernel and thousand-seed weight
Grain unit weight	GOST 10840-64 of Grain. Methods for determining grain unit weight
Vitreousness	GOST 10987-76 Grain. Methods of determining vitreousness
Moisture content	DSTU GOST 29144: 2009 (ISO 711-85) Grain and grain products. Determining moisture content
Quantity and quality of gluten of the grain	GOST 13586.1-68 Grain. Methods of determining the quantity and quality of gluten in wheat
Sedimentation	GOST ISO 5529-2013 Sedimentation. Determining the sedimentation by the Zeleny method (PN - 93/A - 74019)
Crude protein content	GOST 10846-91. Grain and products of its processing. Protein determination method
Acidity	GOST 27493-87. Flour and bran. Method of determining acidity by thin flour dough
Ash content	GOST 10847-74 Grain. Ash determination methods
Quantity and quality of gluten of the flour	GOST 27839-88. Wheat flour. Methods of determination of gluten quantity and quality
Whiteness of the flour	GOST 26361-84. Flour. Method of determining whiteness
Flour granularity (granulometric composition)	GOST 27560-87. Flour. Granularity determination method
Baking test	GOST 27669-88. Wheat bread flour. Method of test laboratory baking

Laboratory milling. To achieve the above objectives, in a laboratory environment, wholegrain flour was obtained from cleaned grains of the *Chornobrova* variety, without hydrothermal treatment, according to the 96% whole-wheat milling structure, but without

separating the bran particles. The following laboratory equipment was used for this purpose:

– an aspiration column designed to clean the grain from dust-like, aerodynamically light impurities. The main components of the machine are: a column with

inclined guides, a fan, battery cyclones, and a filter cloth. The air velocity was 4.5–5.0 m/s;

– a laboratory sifter RLU-1 designed to study the particle size distribution of grain, cereals, and flakes by sifting them on appropriate sieves. The horizontal oscillation frequency was 120/200 rpm, oscillation radius 25 mm, sifting time for a sample 5 min;

– a roller mill *Nagema*, with horizontally arranged smooth rollers 150 mm long and 220 mm in diameter. The ratio of the speed of the rollers was 2.5.

The laboratory milling was carried out on the roller mill and the laboratory sifter with three sieves. Besides, the equipment used also included a laboratory balance, collapsible grain analysis boards, and product containers. The structure of laboratory milling is shown in Fig. 1.

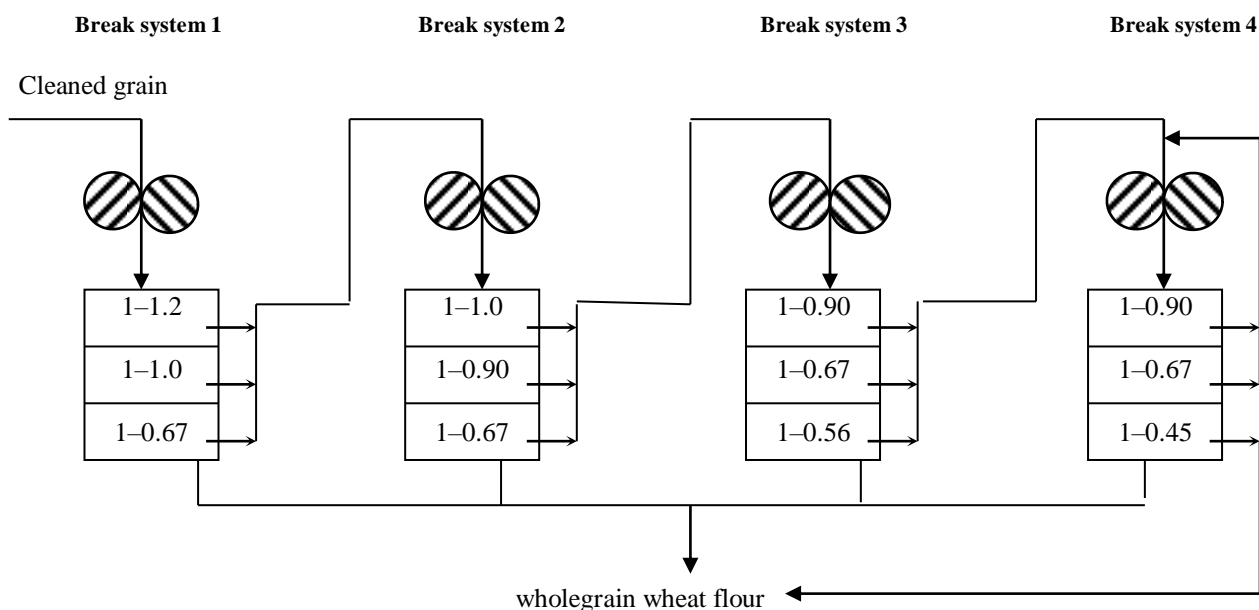

Fig. 1. Structure of laboratory milling

The technical characteristics of the roller mill: the diameter of the rollers $D = 0.22$ m; length of the rollers $L = 0.15$ m; number of riffles (flutes) per 1 cm of the circle of rollers $R = 6$; incline of the riffles $U = 6\%$; ratio of the circular speed of the rollers 2.5.

The laboratory sifter consists of three collapsible sieves that can be replaced depending on the system. Wholegrain flour is obtained by passing the bottom sieve, and the overtail products are sent to the next grinding system. From the fourth break system, the overtail product is returned to the same system for final grinding.

For the wholegrain flour obtained, the quality characteristics were determined, and test baking was performed. As a control sample, products made from traditional wholegrain flour of the TM *Olala* were used. The technological properties of this flour had also been determined. For the test breadbaking, pressed bakery yeast *Lvivski* was used (TU U 10.8-00383320-001). Wholegrain wheat flour of the TM *Olala* and wholegrain rye flour of the TM *Formula Zdorovya* were used as control samples (Table 2).

For the laboratory baking test, the dough was prepared in accordance with the recommendations. In the straight dough procedure, all the flour is used to

make the dough. The temperature of the prepared dough was 28–30°C, the moisture content 44–45%. The total fermentation time when baking bread from high-grade flour at a temperature of 32°C is 180 minutes, with three punches (the first after 90 min, the second after 150 min from the beginning of the fermentation). Punching is made by hand, it is short-term mixing of the dough during fermentation. After the third punch, bread baking moulds are prepared (greased with vegetable oil and heated to a temperature of 32°C). After the fermentation time is over, the dough is put into the pre-prepared moulds. The next stage in the preparation of bread is proofing the dough. Dough is proofed in a thermostat in a humid environment until the dough is ready. Proofing takes 30–40 minutes. Then the loaf-to-be is placed into the oven with a capacity of 2 kW/h, preheated to 230°C. The total baking time is 25 minutes.

The quality of bread was evaluated the next day after baking (8 to 24 hours after baking). The organoleptic (crust colour, surface texture and condition, taste, smell, crumb colour, size and evenness of the pore distribution) and physicochemical (weight, volume yield, specific bread volume, porosity) parameters were determined.

Table 2 – Quality characteristics of different types of flour

No	Quality parameter	Wholegrain black wheat flour	Wholegrain wheat flour of the TM <i>Olala</i>	Wholegrain rye flour of the TM <i>Formula Zdorovya</i>
1	Colour	Light brown with dark speckles	White with a yellow tinge	Greyish-white, with the inclusion of the grain hulls
2	Smell	Typical of wheat flour, without off-odours, not musty, not mouldy	Typical of wheat flour, without off-odours, not musty, not mouldy	Typical of rye flour, without off-odours, not musty, not mouldy
3	Taste	Typical of wheat flour, without foreign tastes, not acidic, not bitter	Typical of wheat flour, without foreign tastes, not sour, not bitter	Typical of rye flour, without foreign tastes, not sour, not bitter
4	Moisture content, %	12.9	13.0	14.8
5	Acidity, deg. H	2.6	2.5	3.0
6	Amount of crude gluten, %	23.5	24.2	–
7	Gluten deformation index on the device IDK-1, units	73	61	–
8	Colour of gluten	Light brown	Cream-coloured	–
9	Gluten quality group	I	I	–
10	Flour granularity, %: Screening residue, sieve No. 045	–	–	1.5
	Screening residue, sieve No. 067	4	3	–
	Undersize, sieve No. 38	60	29	65

3 sets of experiments were conducted.

Baking test 1 – a study of the baking properties of wholegrain flour from black wheat obtained in a laboratory environment. The control was a wholegrain wheat flour sample of the TM *Olala* manufactured industrially.

Baking test 2 – a study of the baking properties of flour mixtures. The following proportion of flour was used in the baking test: wheat and rye flour – 70/30%, rye and wheat flour – 60/40%, and rye flour – 100%. The material used in the test baking was wholemeal flour from black wheat obtained in a laboratory environment, and dark rye flour of the TM *Formula Zdorovya* obtained industrially by the 80 % dark rye flour milling procedure.

Baking test 3 – a study of the baking properties of wholemeal flour from black wheat obtained in a laboratory environment with the addition of the improver *Top Bake* and the flour whitener *Decolox* in the minimum doses recommended by the manufacturer *Mullenchemi (LLC Stern Ingredients Ukraine)*.

Results of the research and their discussion

An analysis of existing technologies of wholegrain flour production has shown that the simplest milling is carried out according to the wholemeal milling scheme. When using roller mills as grinding equipment, it is possible to adopt a milling scheme consisting of 4 systems with successive grinding of overtail products.

The study of the baking properties of the wholegrain flour obtained from the *Chornobrova* wheat variety is based on analysing the quality of the finished product, bread. At this stage, a test loaf of bread was baked from

the flour obtained, the control being TM *Olala* wheat flour. The quality of the bread was evaluated on the next day (within 8–24 hours after baking). The organoleptic (crust colour, surface texture and condition, taste, smell, crumb colour, size and evenness of the pore distribution) (Table 3) and physicochemical (weight, volume yield, specific bread volume, porosity) (Table 4) parameters were determined.

The control sample was bread baked from traditional wholegrain wheat flour. A comparative analysis of the organoleptic characteristics has shown that the baking test product was similar to the control by all parameters except the shape.

The analysis of the physicochemical characteristics has shown that the test-baked sample meets the requirements of GOST (State Standard) 27842-88 “Ukrainian Palyanytsya” in all parameters: its moisture content does not exceed 48%, nor does its acidity exceed the normative value of 7 °H, nor is the porosity less than the normative value of 55%, despite the widespread opinion that *Chornobrova* grain can only be used to make cereals. Moreover, bakery products made from *Chornobrova* are hardly inferior in quality to those from traditional wheat flour: their moisture content is by 2% less, acidity by 1.1°H higher, and porosity by 6.5% less than those of the control sample. The specific volume of the test sample is 1.1 times less than the control volume due to the low rheological properties of *Chornobrova* gluten. The only significant drawback of the bakery product is its specific colour – almost black.

The quality characteristics of the baking test product from wholegrain wheat flour *Chornobrova* and rye flour

Formula Zdorovya are given in Table 3 and Table 4 (baking test 2). A rye flour sample was selected as a control. A comparative analysis of the organoleptic properties has shown that the *Chornobrova* product differs from the control in the shape and the condition of the surface. The sample is irregularly shaped, and its surface is cracked and ruptured. But the specific volume and porosity of the *Chornobrova* bread are better.

As the physical and chemical parameters of the test sample are within normal limits, it is possible to find the proportion of wheat flour and rye flour to avoid the organoleptic problems. In the baking test, wholegrain *Chornobrova* wheat flour obtained in a laboratory environment was used. The *Top Bake* enhancer was added to improve the quality of bread, of its gluten, etc. and the *Decolox* whitener was added for a good whitening effect, though it does not strengthen the gluten. The doses

of the technological additives were those recommended by the manufacturer (*Muhlenchemie*): *Top Bake Ban Bread* – 0.5%, and *Decolox 32*–0.015% (baking test 3, Tables 3, 4).

Not all the organoleptic parameters of bread noticeably change due to the improvement. For example, the shape of the baking test product was irregular, and the surface with cracks and ruptures. The comparative analysis of the physical and chemical properties of the test-baked bread has shown that it meets the requirements of DSTU 2077-88: the moisture content does not exceed 50 %, the acidity does not exceed 10°H, the porosity is not lower than 56%. So, it can be concluded that if the physical and chemical parameters of the baking test are within the normal range, its external characteristics can be made better by changing the dosage of the additives or the baking parameters.

Table 3 – Organoleptic quality parameters of the baking test products

Flour sample		Shape	Condition of the surface	Colour	Flavour and odour	Crumb condition
Baking test 1	<i>Chornobrova</i>	Irregular, with the convex crust top	With cracks and ruptures	Brown	Typical of this product, without foreign odours and flavours	Fine and even porosity
	<i>Olala</i>	Regular, with the convex crust top	With cracks and ruptures	Golden	Typical of this product, without foreign odours and flavours	Fine and even porosity
Baking test 2	Wheat and rye	Irregular, with the convex crust top	With cracks and ruptures	Brown	Particular to this product	Fine and even porosity
	Rye and wheat	Irregular, with the convex crust top	With cracks and ruptures	Brown	Typical of this product, without foreign odours and flavours	Fine and even porosity
	Rye	Regular, with the convex crust top	Smooth	Light brown	Particular to this product	Fine and even porosity
Baking test 3	<i>Decolox</i>	Irregular, with the convex crust top	With cracks and ruptures	Brown	Typical of this product, without foreign odours and flavours	Fine and even porosity
	<i>Top Bake Ban Bread</i>	Irregular, with convex upper crust	With cracks and ruptures	Brown	Typical of this product, without foreign odours and flavours	Fine and even porosity

Table 4 – Physical and chemical parameters of the baking test products

Flour sample		Moisture content, %	Acidity, °H	Volume, cm ³	Porosity, %	Specific volume, cm ³ /g
Baking test 1	<i>Chornobrova</i>	43.7	2.8	420	67.0	2.0
	<i>Olala</i>	45.0	1.7	515	73.5	2.3
Baking test 2	Wheat and rye	43.5	5.8	290	63.0	1.3
	Rye and wheat	44.4	5.9	250	62.5	1.1
	Rye	44.0	6.1	190	60.0	0.9
Baking test 3	<i>Decolox</i>	42.2	4.9	410	72.5	2.0
	<i>Top Bake Ban Bread</i>	42.9	5.9	505	82.5	2.5

Conclusion

Thus, on the basis of the research, the article proves the feasibility of producing wholegrain flour from black

wheat of improved biological value. The basic technological and baking properties of wheat of the *Chornobrova* variety have been determined, as well as those of the wholegrain flour obtained from it in a laboratory environment. The parameters of the test-

baked bread from wholegrain flour, with and without different additives, have been studied. It has been recommended to bake it with addition of 0.5% of the *Top Bake Ban Bread* improver, or using the wheat and rye mixture, because this will not only improve the traditional colour of rye bread, but its properties as well. In the future, it is necessary to study carefully the

chemical composition of wholegrain black wheat flour, to establish how it changes during baking, to substantiate the size of this flour, and to improve its production technology. This is going to allow its wider use in food products, and will certainly contribute to improving the Ukrainian people's health.

References:

1. Reproduktyvne zdorov'ya natsiyi: Postanova KMU «Pro zatverdzhennya Derzhavnoyi prohramy» vid 27.12.2006 № 1849/Ofitsiynny visnyk Ukrainy. 2007; 1:129-156.
2. Spirichev VB, Shatnyuk LN, Pozdnyakovskiy VM. Obohashchenie pishchevykh produktov mikronutrientami: nauchnye podkhody i prakticheskie resheniya. Pishchevaya promyshlennost'. 2003;3:10-17.
3. Pro skhvalennya proektu Kontseptsiyi Derzhavnoyi naukovo-tekhnichnoyi prohramy «Biofortyfikatsiya ta funktsional'ni produkty na osnovi roslynnoyi syrovyny na 2012 - 2016 roky»: Postanova NAN Ukrainy vid 08.06.2011 № 189. URL: http://search.ligazakon.ua/l_doc2.nsf/link1/MUS17448.html. (data zvernennya 20.10.2018).
4. Ficco DBM, et al. Genetic variability in anthocyanin composition and nutritional properties of blue, purple, and red bread (*Triticum aestivum* L.) and durum (*Triticum turgidum* L. ssp. *turgidum* convar. *durum*) wheats. J. Agric. Food Chem. 2014; 62(34):8686-8695. DOI 10.1021/jf5003683,
5. Polonskiy VI, Loskutov IH, Sumina AV. Seleksiya na sodержanie antioksidantov v zerne kak perspektivnoe napravlenie dlya polucheniya produktov zdorovogo pitaniya. Vavilovskiy zhurnal genetiki i selektsii. 2018; 22 (3):343-352. doi.org/10.18699/VJ18.370
6. Khlstskina EK et al. Marker-kontroliruemoe poluchenie i proizvodstvo form pshenitsy s povyshennym urovnem bioflavonoidov: otsenka produktsii dlya obosnovaniya znachimosti napravleniya. Vavilovskiy zhurnal genetiki i selektsii. 2017; 21(5):545-553. doi.org/10.18699/VJ17.25-o
7. Derzhavnyy reyestr sortiv roslyn, prydatnykh dlya poshyrennya v Ukraini na 2018 rik/Ministerstvo ahramoyi polityky ta prodovol'stva Ukrainy. K; 2018.
8. Dong YJ, et al. Genomic regions associated with the degree of red coloration in pericarp of rice (*Oryza sativa* L.). J. Cereal Sci. 2008;48(2):556-560. DOI 10.1016/j.jcs.2007.11.011.
9. Chen XQ et al. Anti-oxidative analysis, and identification and quantification of anthocyanin pigments in different coloured rice. Food Chem. 2012; 135(4):2783-2788. DOI 10.1016/j.foodchem.2012.06.098.
10. Maeda H et al. Genetic dissection of black grain rice by the development of a near isogenic line. Breed Sci. 2014; 64(2):134-141. DOI 10.1270/jsbbs.64.134.
11. Ahuja U, et al. Red rices – past, present, and future. Asian Agri. Hist. 2007;11:291-304.
12. Bordiga M et al. Phenolics characterization and antioxidant activity of six different pigmented *Oryza sativa* L. cultivars grown in Piedmont (Italy). Food Res. Int. 2014; 65(Part B):282-290. DOI 10.1016/j.foodres.2014.03.007.
13. Cho YH et al. Evaluating Korean rice genotypes and landraces for octacosanol contents and antioxidant activity. Natural product research. 2017;31(23):2778-2782. DOI:10.1080/14786419.2017.1292271.
14. Goncharova YUK et al. Chernozernyy i krasnozernyy ris – super-pishcha 21 veka. Pishcha. Ekologiya. Kachestvo. 2017:163-165.
15. Zelenskiy GL. et al. Rossiyskiye krasnozernyye sorta risa, sozdannyye dlya lechebnogo pitaniya. AgroSnabForum. 2017; 6:58-63.
16. Pereira-Caro G et al. Phytochemical profiles of black, red, brown, and white rice from the Camargue region of France. Journal of agricultural and food chemistry. 2013;61(33):7976-7986. DOI: 10.1021/jf401937b
17. Hryaznov AA Muka iz zerna pihmentirovannogo sorta yachmenya kak komponent konditerskikh izdeliy. Ahroprodovol'stvennaya politika Rossii. 2015;1(5):51-54.
18. Abdel-Aal ESM, Hucl P. Composition and stability of anthocyanins in blue-grained wheat. Journal of Agricultural and food Chemistry. 2003; 51(8):2174-2180.
19. Li W et al. Protein characteristics of Chinese black-grained wheat. Food chemistry. 2006;98(3):463-472.
20. Li W, Beta T. Flour and bread from black-, purple-, and blue-colored wheats. Flour and breads and their fortification in health and disease prevention. 2011: 59-67. doi.org/10.1016/B978-0-12-380886-8.10006-6
21. Li W et al. Free radical scavenging properties and phenolic content of Chinese black-grained wheat. Journal of agricultural and food chemistry. 2005; 53 (22):8533-8536.
22. Toporash IG, Zhigunov DA, Aksel'rud DV. Issledovaniye tekhnologicheskikh svoystv sovremennykh sortov pshenitsy Ukrainy I. Fizicheskkiye i biokhimicheskiye pokazateli kachestva zerna. Zernoviy produkti i kombikormi. 2012; 2:30-35. doi.org/10.15673/2313-478x.58/2015.46008.
23. Rybalka OI, Polishchuk SS. Novi sorty zernovykh kul'tur dlya stvorenniya produktiv zdorovogo (funktsional'nogo) kharchuvannya. Zbirnyk naukovykh prats' Seleksiyno-henetychnoho instytutu-Natsional'nogo tsentru nasinneznastva ta sortovyvchennya. 2013; 22:13-26.
24. Li Y et al. Total phenolic, flavonoid content, and antioxidant activity of flour, noodles, and steamed bread made from different colored wheat grains by three milling methods. The Crop Journal. 2015;3(4):328-334. doi: 10.1016/j.cj.2015.04.004

ДОСЛІДЖЕННЯ ХЛІБОПЕКАРСЬКИХ ВЛАСТИВОСТЕЙ ЦІЛЬНОЗМЕЛЕННОГО БОРОШНА З ЧОРНОЗЕРНОЇ ПШЕНИЦІ

Д.О. Жигунов, доктор технічних наук, доцент¹, E-mail: dimius75@gmail.com

Н. В. Хоренжий, кандидат технічних наук, доцент¹, E-mail: natalka.onaft@gmail.com

О.С. Волошенко, кандидат технічних наук, доцент¹, E-mail: voloshenko.kroshko@gmail.com

Г.Д. Жигунова², магістр, E-mail: hanna.zhyhunova@gmail.com

¹Кафедра технології переробки зерна

²Кафедра технології зберігання зерна

Одеська національна академія харчових технологій, м. Одеса, вул. Канатна, Україна, 65039

Анотація. Статтю присвячено вивченню цільового призначення нового сорту пшениці з підвищеною біологічною цінністю – Чорноброва. Показано, що для забезпечення здоров'я нації актуальним є підвищення харчової цінності борошна шляхом збільшення вмісту основних харчових речовин (білків) і незамінних мікронутрієнтів, зокрема біофортificaції рослин. Науковці у всьому світі активно працюють в аспекті біофортificaції над так званим «забарвленим» або пігментованим зерном ячменю, пшениці, рису з метою підвищення його біологічної цінності та створення з них продуктів функціонального (оздоровчого) харчування. З усього різноманіття нових сортів «забарвленого» зерна найменш вивченим є пшениця, зокрема чорнозерна. Метою роботи є обґрунтування доцільності виготовлення з чорнозерної пшениці цільнозернового борошна підвищеної біологічної цінності. Для досягнення поставленої мети необхідно вирішити такі задачі: визначити основні технологічні та хлібопекарські властивості пшениці чорнозерної сорту Чорноброва та цільнозернового борошна з неї; дослідити показники пробної випічки хліба з цільнозернового борошна без та із додаванням різних добавок. Предметами досліджень є зерно пшениці чорнозерної Чорноброва, отримане з неї цільнозернове борошно та модельні суміші. Використовували зерно пшениці врожаю 2016 року, що зберігалось протягом 12 місяців, з наступними показниками якості: вологість 12,6%; вміст сирого протеїну 10,8%; сирій золи 1,53%; сирій клейковини 23%; група якості клейковини I, седиментація 33 мл; натура 733 г/л; маса 1000 зерен 40 г; склоподібність 68%. В отриманому у лабораторних умовах цільнозерновому борошні визначено показники якості: колір – світло-коричневий з темними вкрапинами, запах та смак властивий пшеничному борошну, вологість 12,9%, вміст сирій клейковини 23,5%, група якості клейковини I, колір клейковини світлокоричневий, кислотність 2,6°Н, крупність борошна – залишок на ситі 067–4%, а прохід сита 38–60%. Проведено серію дослідів та встановлено, що хлібобулочні вироби з пшениці сорту Чорноброва майже не поступаються якістю хлібопекарським виробам із борошна звичайної пшениці: на 2% менша вологість, на 1,1°Н вища кислотність, на 6,5% менша пористість за контрольний зразок. Питомий об'єм дослідного зразка на 14% менший за контрольний, що пов'язано з низькими реологічними властивостями клейковини пшениці сорту Чорноброва. Єдиний суттєвий недолік хлібопекарського виробу полягає у специфічному кольорі – майже чорному. Додавання ж до складу випічки освітлювача у кількості 0,015% цей недолік не компенсувало, а покращувача – дещо збільшило пористість та питомий об'єм хлібу. Таким чином на підставі проведених досліджень в статті обґрунтовано доцільність виготовлення з чорнозерної пшениці цільнозернового борошна, що буде володіти підвищеною біологічною цінністю. Визначено основні технологічні та хлібопекарські властивості пшениці чорнозерної сорту Чорноброва, отриманого в лабораторних умовах цільнозернового борошна з неї. Досліджено показники пробної випічки хлібу з цільнозернового борошна без та із додаванням різних добавок та рекомендовано використовувати його із затосуванням покращувача Top Bake Van Bread 0,5% або у суміші житньо-пшеничний, що дасть змогу не тільки покращити традиційний колір хлібу, але й властивості цього виробу.

Ключові слова: біологічна цінність, чорнозерна пшениця, цільнозернове борошно, хлібопекарські властивості.

Список літератури:

1. Репродуктивне здоров'я нації: Постанова КМУ «Про затвердження Державної програми» від 27.12.2006 № 1849/Офіційний вісник України. 2007. вип.1. С. 129-156.
2. Спиричев В.Б., Шатнюк Л.Н., Поздняковский В.М. Обогащение пищевых продуктов микронутриентами: научные подходы и практические решения//Пищевая промышленность. 2003. № 3. С. 10-17.
3. Про схвалення проекту Концепції Державної науково-технічної програми «Біофортificaція та функціональні продукти на основі рослинної сировини на 2012 - 2016 роки»: Постанова НАН України від 08.06.2011 № 189. URL:http://search.ligazakon.ua/1_doc2.nsf/link1/MUS17448.html. (дата звернення 20.10.2018).
4. Genetic variability in anthocyanin composition and nutritional properties of blue, purple, and red bread (*Triticum aestivum* L.) and durum (*Triticum turgidum* L. ssp. *turgidum* convar. *durum*) wheats/Ficco D.B.M., et al. // J. Agric. Food Chem. 2014. Vol. 62, Issue 34. P.8686-8695. DOI 10.1021/jf5003683/
5. Полонский В.И., Лоскутов И.Г., Сумина А.В. Селекция на содержание антиоксидантов в зерне как перспективное направление для получения продуктов здорового питания // Вавиловский журнал генетики и селекции. 2018. Т. 22, №. 3. С. 343-352. doi.org/10.18699/VJ18.370.
6. Маркер-контролируемое получение и производство форм пшеницы с повышенным уровнем биофлавоноидов: оценка продукции для обоснования значимости направления/Хлесткина Е.К. и др. // Вавиловский журнал генетики и селекции. 2017. Т. 21, №. 5. С. 545-553. doi.org/10.18699/VJ17.25-0.
7. Державний реєстр сортів рослин, придатних для поширення в Україні на 2018 рік/Міністерство аграрної політики та продовольства України. К. 2018. 467 с.
8. Genomic regions associated with the degree of red coloration in pericarp of rice (*Oryza sativa* L.)/Dong Y.J.et al. // J. Cereal Sci. 2008. Т. 48, № 2. P. 556- 560. DOI 10.1016/j.jcs.2007.11.011.
9. Anti-oxidative analysis, and identification and quantification of anthocyanin pigments in different coloured rice./Chen XQ, et al. // Food Chem. 2012. Т. 135, № 4. P. 2783-2788. DOI 10.1016/j. foodchem.2012.06.098.
10. Genetic dissection of black grain rice by the development of a near isogenic line/Maeda H., et al. // Breed Sci. 2014. Т. 64, № 2. P. 134-141. DOI 10.1270/jsbbs.64.134.
11. Red rices – past, present, and future./Ahuja U., et al. // Asian Agri. Hist. 2007. № 11. P. 291-304.
12. Phenolics characterization and antioxidant activity of six different pigmented *Oryza sativa* L. cultivars grown in Piedmont (Italy)/Bordiga M., et al. // Food Res. Int. 2014. № 65 (Part B). P. 282-290. DOI 10.1016/j. foodres.2014.03.007.
13. Evaluating Korean rice genotypes and landraces for octacosanol contents and antioxidant activity/Cho Y. H. et al. // Natural product research. 2017. Т. 31, № 23. P. 2778-2782. DOI:10.1080/14786419.2017.1292271
14. Чернозерный и краснозерный рис – супер-пища 21 века/Гончарова Ю. К. и др. // Пища. Экология. Качество. 2017. С. 163-165.
15. Российские краснозерные сорта риса, созданные для лечебного питания/Зеленский Г. Л. и др. // АгроСнабФорум. 2017. №. 6. С. 58-63.
16. Phytochemical profiles of black, red, brown, and white rice from the Camargue region of France ./Pereira-Caro G. et al. // Journal of agricultural and food chemistry. 2013. Т. 61, № 33. P. 7976-7986. DOI: 10.1021/jf401937b

17. Грязнов А.А. Мука из зерна пигментированного сорта ячменя как компонент кондитерских изделий // Агропродовольственная политика России. 2015. № 6. С. 51-54.
18. Abdel-Aal E.S.M., Hucl P. Composition and stability of anthocyanins in blue-grained wheat // Journal of Agricultural and food Chemistry. 2003. Т. 51 № 8. P. 2174-2180.
19. Protein characteristics of Chinese black-grained wheat / Li W. et al. // Food chemistry. 2006. Т. 98, № 3. P. 463-472.
20. Li W., Beta T. Flour and bread from black-, purple-, and blue-colored wheats. Flour and breads and their fortification in health and disease prevention. 2011. P. 59-67. doi.org/10.1016/B978-0-12-380886-8.10006-6
21. Free radical scavenging properties and phenolic content of Chinese black-grained wheat / Li W. et al // Journal of agricultural and food chemistry. 2005. Т. 53, № 22. P. 8533-8536.
22. Топораш І.Г., Жигунов Д.А., Аксельруд Д.В. Исследование технологических свойств современных сортов пшеницы Украины І. Физические и биохимические показатели качества зерна // Зернові продукти і комбікорми. 2012. № 2. С. 30-35. doi.org/10.15673/2313-478x.58/2015.46008
23. Рибалка О.І., Поліщук С.С. Нові сорти зернових культур для створення продуктів здорового (функціонального) харчування // Збірник наукових праць Селекційно-генетичного інституту-Національного центру насіннєзнавства та сортовивчення. 2013. № 22. С. 13-26.
24. Total phenolic, flavonoid content, and antioxidant activity of flour, noodles, and steamed bread made from different colored wheat grains by three milling methods /Li Y. et al. // The Crop Journal. 2015. Т. 3, № 4. P. 328-334. doi: 10.1016/j.cj.2015.04.004