



[5] Application programming interface [Електронний ресурс] – Режим доступу до ресурсу: [https://en.wikipedia.org/wiki/Application\\_programming\\_interface](https://en.wikipedia.org/wiki/Application_programming_interface)

### References

[1] “Web application,” *Wikipedia*, 28-Jan-2018. [Online]. Available: [https://en.wikipedia.org/wiki/Web\\_application](https://en.wikipedia.org/wiki/Web_application). [Accessed: 30-Jan-2018].

[2] “Client–server model,” *Wikipedia*, 29-Mar-2018. [Online]. Available: [https://en.wikipedia.org/wiki/Client–server\\_model](https://en.wikipedia.org/wiki/Client–server_model). [Accessed: 30-Apr-2018].

[3] Single-page application,” *Wikipedia*, 30-Jun-2017. [Online]. Available: [https://en.wikipedia.org/wiki/Single-page\\_application](https://en.wikipedia.org/wiki/Single-page_application). [Accessed: 30-Jun-2017].

[4] “Representational state transfer,” *Wikipedia*, 12-Jul-2017. [Online]. Available: [https://en.wikipedia.org/wiki/Representational\\_state\\_transfer](https://en.wikipedia.org/wiki/Representational_state_transfer). [Accessed: 30-Jan-2018].

[5] “Application programming interface,” *Wikipedia*, 9-Jan-2018. [Online]. Available: [https://en.wikipedia.org/wiki/Application\\_programming\\_interface](https://en.wikipedia.org/wiki/Application_programming_interface). [Accessed: 10-Jan-2018].

УДК 681.52

## RESEARCH OF THE PROGRAMMERS FOR CONTROL OF THE PERIODIC ACTION OBJECTS WITH NON-LINEAR TIME PROGRAM

Klymenko<sup>1</sup> O., Krong<sup>2</sup> E., Tregub<sup>3</sup> V.

<sup>1</sup>National University of Food Technologies, Kyiv, Ukraine

E-mail: Frank.\_.s@bigmir.net

Copyright © 2018 by author and the journal “Automation technologies and business - processes.

This work is licensed under the Creative Commons Attribution International License (CC BY).

<http://creativecommons.org/licenses/by/4.0>

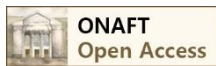

DOI: 10.15673/atbp.v10i2.975

**Abstract.** Not a few devices of food production work periodically and programmers are widely used to control these devices. Using logical devices that transfer between program sections can significantly improve the quality of control, but these methods are not sufficiently studied.

The research is devoted to the development of a programmer for the implementation of programs with nonlinear time areas, containing logical devices in its structure. Single-loop and combined programmable automatic control system (ACS) with logical devices and without them were investigated and a comparative analysis of their work was performed.

**Keywords:** programmer, automatic control system, non-linear time areas.

**Introduction.** For this study, a widespread program of regulation (Figure 1) has been selected, which has such time areas as a growth area of the regulated value (time interval  $T_1$ ), the endurance area at reaching the set value of the regulated value ( $T_2$ ) and the descent area ( $T_3$ ). Growth and endurance areas are linear in time with first-order staticism. For the descent area, if it is known that the autoclave uses first the shower, and then the water cooling, we make an assumption that it will be nonlinear and then there will be second-order staticism.

A program of the periodic process of canned sterilization [1] can serve as an example of such program. The process of sterilization occurs under the same technological regulation. The heating of the autoclave is carried out to the sterilization temperature, and then occurs the actual sterilization, after which the cooled water in the form of a shower is fed to the autoclave, and then after a certain time, cold water is fed for traditional water cooling.

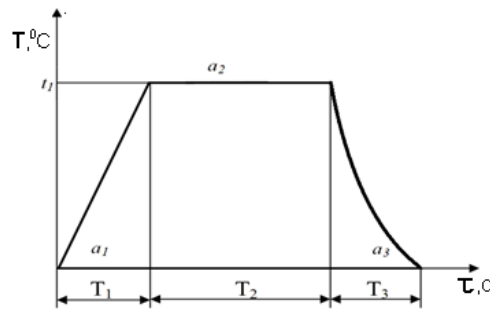

**Fig. 1. Program of regulation**

The research was carried out by using the Matlab package. The mathematical model of the object consisted of the transfer functions of the autoclave (1) and the resistance thermometer (2), respectively

$$W_a(p) = \frac{K_a \cdot e^{-p\tau_a}}{T_a^2 p^2 + 2\lambda T_a p + 1} \quad (1)$$

where  $W_a(p)$  is the transfer function of the autoclave described by the second-order inertial link and the delay link;  $K_a$  is the autoclave transmission coefficient;  $T_a$  - time constant of the inertial link of the second order;  $\lambda$  - coefficient of damping;  $\tau_a$  - time delay constant of the delay link;  $p$  is the Laplace operator.

$$W_T(p) = \frac{K_T}{T_T p + 1} \quad (2)$$

where  $W_T(p)$  is the transfer function of the resistance thermometer;  $K_T$  is the transfer coefficient of the resistance thermometer;  $T_T$  is a time constant.

For further calculations, the following values of the parameters of functions (1) and (2) are taken:  $K_a = 1$ ;  $T_a = 250c$ ;  $\tau_a = 20c$ ;  $\lambda = 4$ ;  $K_T = 1$ ;  $T_T = 100c$ .

The scheme of simulation of a system with a single-loop programmer [2] without logical devices (Figure 2) worked like this: the time characteristics of the program change were pre-set in the Repeating Sequence block, and then the signal from the Repeating Sequence Interpolated get to the Multiport-Switch, which, depending on the time, carried over the value of the temperature task from one of its inputs to the output. At the first input there was a linear section of growth (heating); at the 2nd input - also a linear section of endurance (the sterilization); at the 3rd entry - a section of the program that implements nonlinearities in time with the help of two links connected in parallel, namely the aperiodic link of the 1st order and the real differentiating link.

The task from Repeating Sequence Interpolated and the signal from the feedback came to adder (Add) to form a disagreement. The signal from the regulator passed through the object and the temperature value was displayed on the graph in the Scope and arrived at the calculation of the optimality criterion. To assess the quality of the regulatory process, an integral-modular optimization criterion was used, calculated by the formula:

$$I = \int_{\tau_0}^{\tau_k} |\Delta t(\tau)| d\tau$$

where  $\Delta t(\tau)$  is the value of the controlled variable in time.

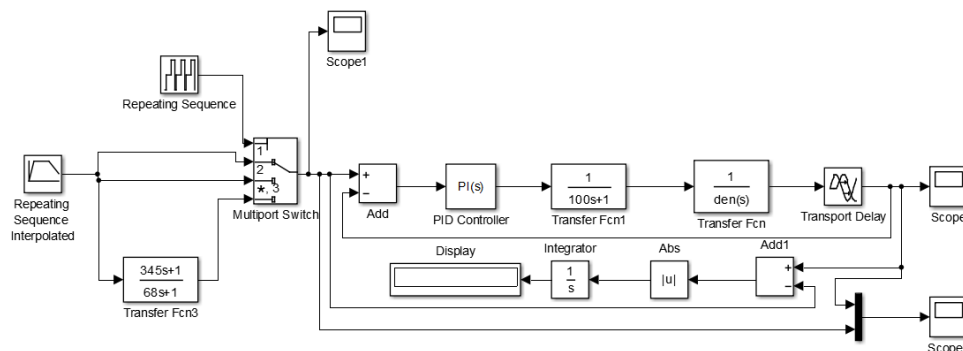

**Fig. 2. Simulation scheme of a single-loop programmable ACS with non-linear section and without logical devices**



As a result of the simulation of a single-loop programmable ACS with a nonlinear section and without logical devices (Figure 3), the optimization criterion was 23565 °C·s. Since the deviation of the temperature from the task exceeded the permissible limits (at some parts of the program it reached 12 °C), and the optimization criterion was very great value, we tried to achieve the required quality control under the technological regulation with the help of single-loop programmable ACS with logical devices (LD).

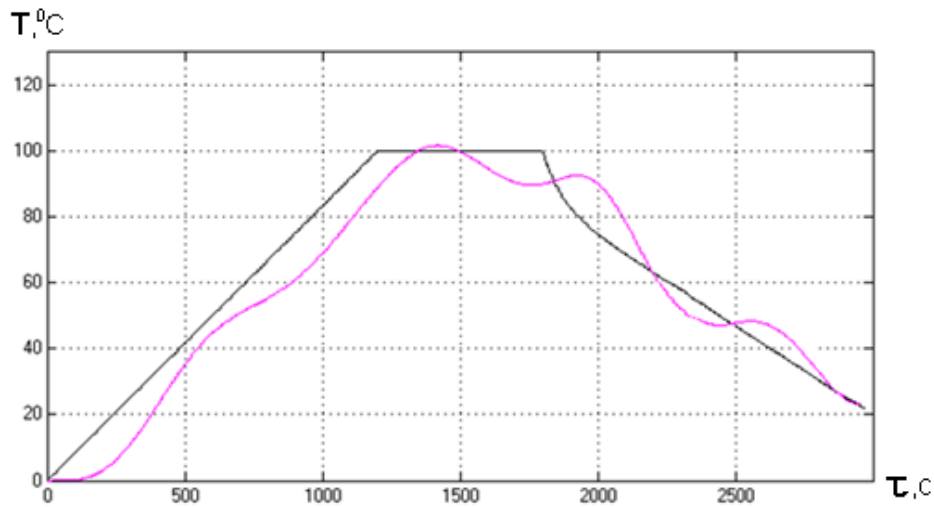

**Fig. 3. Result of the simulation of a single-loop programmable ACS with a nonlinear section and without logical devices**

The scheme with logic devices (Figure 4) worked like this: Repeating Sequence Interpolated filed a task on the adder, which also received a signal from the feedback. The PI regulator with the optimal settings for this area worked on each of the areas. To do this, the Multiport Switch was used, which connected the exit and the input whose number was applied to the first input. The Repeating Sequence set the time (Time values: [0 1200 1200 1680 1680 2880]) and the input number (Output values: [1 1 2 2 3 3]). Thus, the first 1200 s signal came from the first regulator, from 1200 to 1680 s - from the second, and then from the third.

The optimal settings of the regulators in the ACS with logical devices were determined in such a sequence [3]. Initially, the value, which was found in the ACS without logical devices, was set in all regulators. Next, the settings of the regulator were changed at the growth area to improve the optimality criterion, also were changed the settings at the endurance area, and then at the descent area. This process was repeated several times before finding the best results.

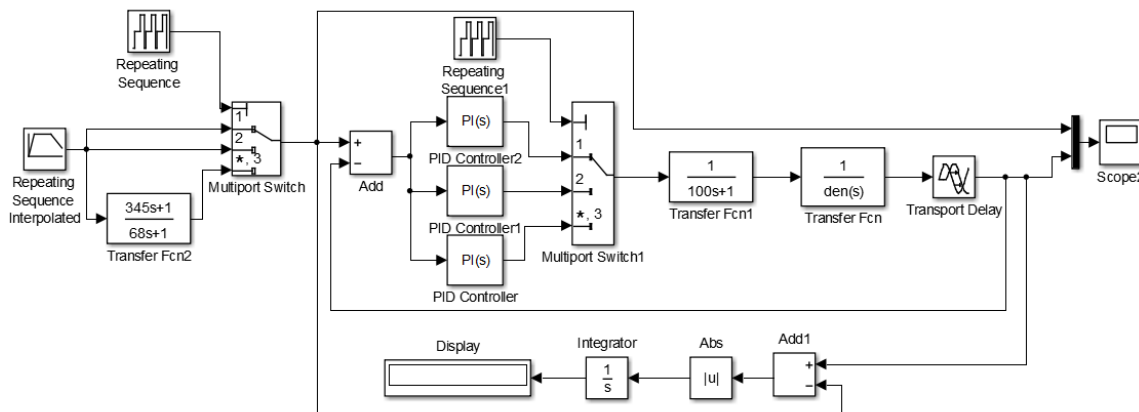

**Fig. 4. Simulation scheme of a single-loop programmable ACS with non-linear section and with logical devices**

As a result of the simulation of a single-loop programmable ACS with a nonlinear section and with logic devices (Figure 5), the optimization criterion was 15126 °C·s. The improvement compared to the previous scheme was more than 35%, but the results for the temperature deviation from the task were still not satisfactory. Therefore, the combined programmable ACS without logical device was considered further.

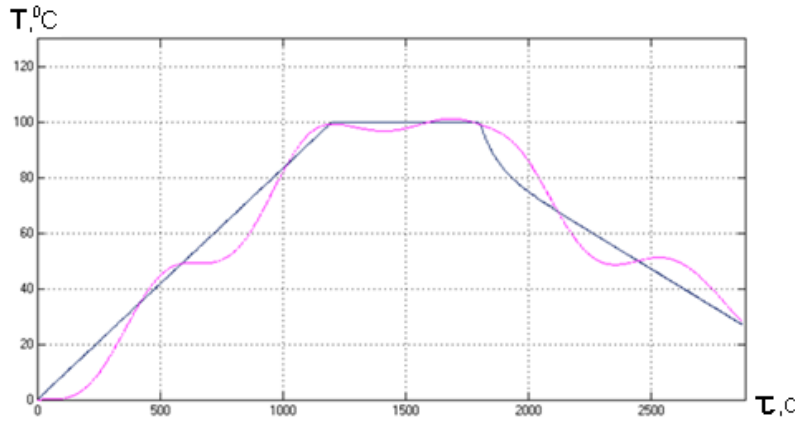

**Fig. 5. Result of the simulation of a single-loop programmable ACS with a nonlinear section and with logical devices**

For a combined ACS, the modeling scheme of which is depicted in Fig. 6, the transfer function of the compensator  $W_k(p)$  is calculated by the formula:

$$W_k(p) = \frac{1}{W_{ob}(p)}$$

Where  $W_{ob}(p) = W_T(p) \cdot W_a(p) = \frac{1}{6250000 p^3 + 162500 p^2 + 1100 p + 1}$

In this case,  $W_k(p)$  does not meet the conditions for physical implementation, since the degree of the polynomial of the numerator must be less than or equal to the degree of polynomial of the denominator. Therefore, we replace it with an approximate transmitted function:

$$W_k(p) = \frac{6250000 p^3 + 162500 p^2 + 1100 p + 1}{p^3 + p^2 + p + 1}$$

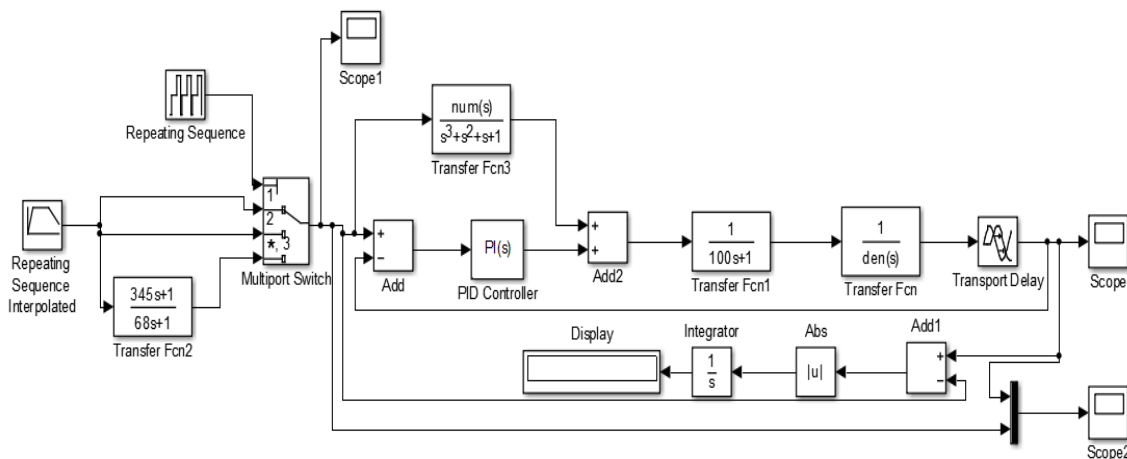
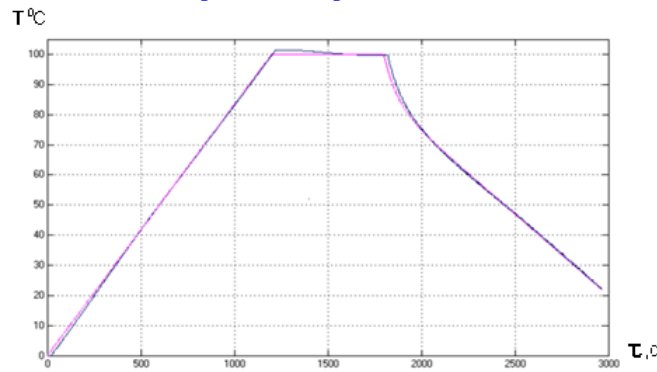

**Fig. 6. Simulation scheme of a combined programmable ACS with non-linear section and without logical devices**

This scheme works like this [4]: Repeating Sequence Interpolated submits a task to the compensator represented by the TransferFnc3 link, and to the adder on which the feedback signal is received. The signal from the regulator is summed with a signal from the compensator. The settings of the regulator are calculated in the same way as in the scheme of single-loop programmable ACS, whose optimal settings are taken under the initial conditions.

As a result of the simulation of a combined programmable ACS with a nonlinear section and without logical devices (Figure 7), the optimization criterion was 1975 °C·s. The improvement compared to the previous scheme was more than 85%, the transition process meets the requirements of the technological regulations. However, the use of logical devices can provide further improvement.

The scheme of combined programmable ACS with logic devices in MatLab is shown in Figure 8.

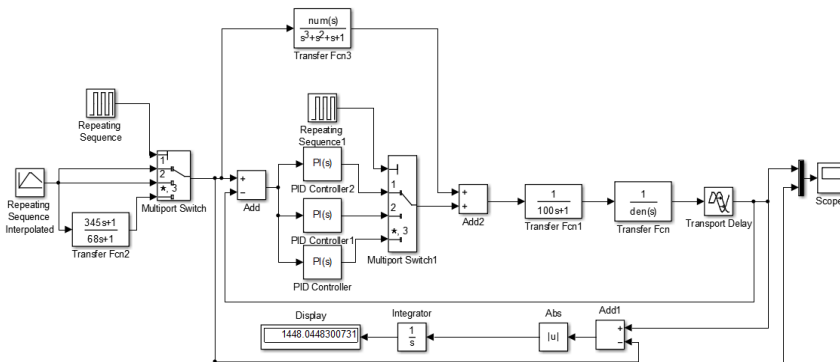

**Fig. 7. Result of the simulation of a combined programmable ACS with a nonlinear section and without logical devices**

Repeating Sequence Interpolated submitted a task to the compensator and to the adder, which also received a signal from the feedback. The value of the disagreement was submitted to the regulator. The PI regulator with the optimal settings for this area worked on each of the areas. To do this, the Multiport Switch was used, which connected the exit and the input whose number was applied to the first input. The Repeating Sequence set the time (Time values: [0 1200 1200 1680 1680 2880]) and the input number (Output values: [1 1 2 2 3 3]). Thus, the first 1200 s signal came from the first regulator, from 1200 to 1680 s - from the second, and then from the third. The signal from the regulator was summed with a signal from the compensator. The signal from the regulator passed through the object and the temperature value was displayed on the graph in the Scope and arrived at the calculation of the optimality criterion.

As a result of the simulation of a combined programmable ACS with a nonlinear site and with logical devices (Figure 9), the optimization criterion was 1862  $^{\circ}\text{C}\cdot\text{s}$ , which is more than 5% better than the scheme without logical devices; the transition process meets the requirements of the technological regulations.

Comparison of the values of the optimality criterion for different types of programmable ACS with a nonlinear section and standard regulators is given in Table 1, where the type of program is the duration of the growth, endurance and descent areas respectively.



**Fig. 8. Simulation scheme of a combined programmable ACS with non-linear section and with logical devices**

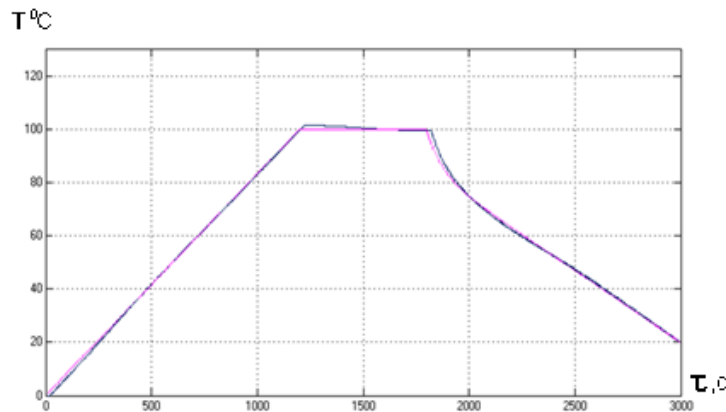

**Fig. 9. Result of the simulation of a combined programmable ACS with a nonlinear section and with logical devices**

**Table 1 - Comparison of the values of the optimality criterion**

Type of program, min	Optimization criterion, °C·s			
	Single-loop ACS without LD	Single-loop ACS with LD	Combined ACS without LD	Combined ACS with LD
25-5-25	15 473	13 222	1 660	1 448
20-8-20	19 508	14 688	1 996	1 997
20-10-20	23 565	15 127	1 976	1 863
20-30-20	34 084	19 002	2 681	2 384
10-40-25	29 390	16 242	4 239	2 854

**Conclusions.** The use of logical devices in the transition between program sections and the introduction of compensators in the system give a significant improvement in the quality of program control in the presence of nonlinear time sections. The error in the integral-modular criterion in the combined program ACS with the use of LD is 7 times less than the error of the single-loop system with using the LD and 11 times less than the error in the single-loop system without using the LD.

The use of LD made it possible to more accurately reproduce the program and reduce the specified error in almost all program variants. It is also worth noting that schemes with logic devices have high efficiency, since it is possible to customize each section separately, which is important not only for the program control of autoclaves, but also for program control of other periodic devices.

#### Список використаної літератури

1. Бабарин В.П. Стерилизация консервов: справочник / В.П. Бабарин. – СПб.: ГИОРД, 2006. – 312с.
2. Клименко О.М. Дослідження програматорів для систем управління апаратами періодичної дії / О.М. Клименко, В.Г. Трегуб // Наукові праці НУХТ № 42. – Київ: НУХТ, 2012. – С.11 – 16.
3. Гоголюк П.Ф., Теорія автоматичного керування: навчальний посібник / П.Ф.Гоголюк, Т.М.Гречин.– Львів: Видавництво Національного університету “Львівська політехніка”, 2009.– 280с.
4. Гультьев А.К. Визуальное моделирование в среде MATLAB6 / А.К. Гультьев. – СПб.: Питер, 2000.–432с.

УДК 519.852.33

## ЭЛЕКТРИЧЕСКАЯ МОДЕЛЬ С ИДЕАЛЬНЫМИ ЭЛЕМЕНТАМИ ДЛЯ ПОИСКА КРАТЧАЙШЕГО ПУТИ НА ВЗВЕШЕННОМ ОРИЕНТИРОВАННОМ ГРАФЕ

Гнатенко В.Ю.<sup>1</sup>, Ступень П.В.<sup>2</sup>, Дікусар К.В.<sup>3</sup>, Шутєєв Е.І.<sup>4</sup>

<sup>1,2,3,4</sup>Одесский национальный политехнический университет, г.Одесса, Украина

<sup>1</sup>E-mail: [valera.gnatenko@gmail.com](mailto:valera.gnatenko@gmail.com), <sup>2</sup>[stek2000@gmail.com](mailto:stek2000@gmail.com), <sup>3</sup>[semuella@gmail.com](mailto:semuella@gmail.com), <sup>4</sup>[edshh489@gmail.com](mailto:edshh489@gmail.com)

Copyright © 2018 by author and the journal “Automation technologies and business - processes.

This work is licensed under the Creative Commons Attribution International License (CC BY).

<http://creativecommons.org/licenses/by/4.0>



DOI: 10.15673/atbp.v10i2.976

*Аннотация.* Рассмотрена проблема определения кратчайшего пути во взвешенном ориентированном графе с применением электрической модели с идеальными диодами, источниками напряжения и тока. Проведены теоретические исследования в области математического моделирования электрических схем с идеальными элементами. Рассмотрен пример определения кратчайшего пути в заданном взвешенном ориентированном графе.